

Axis network switches

Configuration guide

About this guide

This switch configuration guide is for network administrators configuring and managing AXIS network switches. It provides information on configuring features mainly through the HTTP/HTTPS web interface. Some of the information is given by using the command line interface. This guide applies to the AXIS T85 series (excl. T8504-E) and AXIS D8208-R switch.

Before using this guide, you should have experience with network switches and be familiar with the concepts and terminology of TCP/IP, Ethernet and POE.

This guide does not cover the installation part. You should check and follow the installation guide for each switch model separately. For the user manuals of AXIS Network Switches, see *here*. For the firmware releases of the network Switches, go to *Network Switch Release Notes*.

Basic

The built-in help manual

The switch has a context-sensitive built-in help. The help provides more detailed information on the product's basic and advanced features and their settings. To access the help content for any given view, click the question mark at the top right corner. Some help content also includes clickable terms and acronyms that are explained in more detail in the built-in glossary.

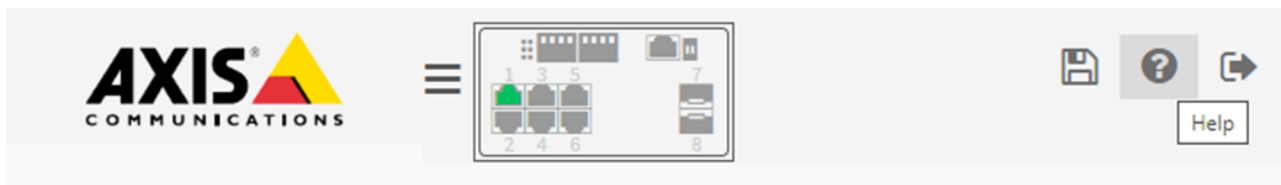

Save the configuration

The "Apply" button only saves the configuration to the running-configuration. The configuration will be lost after the switch reboot. To save the configuration changes, we need to copy the settings to the startup-configuration:

- In the web interface. Click the floppy icon on the top right corner.

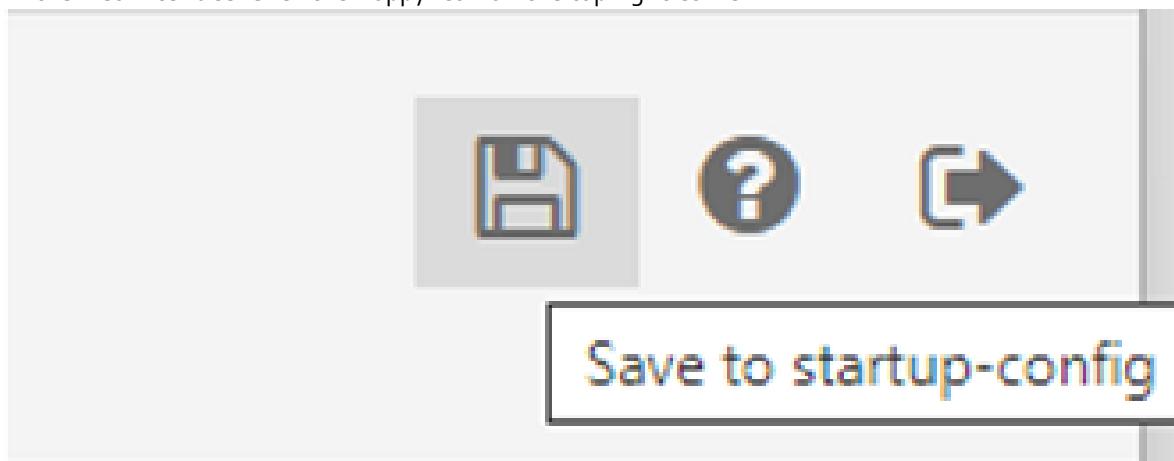

- In the CLI interface. Using the below command.

```
AXIS T85 SW# copy running-config startup-config
```

To avoid potential conflicts, we recommend that you do the configurations for the new switch before connecting it to the existing network in production.

Access the switch

Management IP

In AXIS T85 Switches, the default Management IP address is the IP address of the VLAN1 interface. When multiple VLAN interfaces are created, you can also access the switch via any of the VLAN interfaces as long as they are reachable.

Username and password

The default username and password are on the product label underneath the switch.

Access the web interface

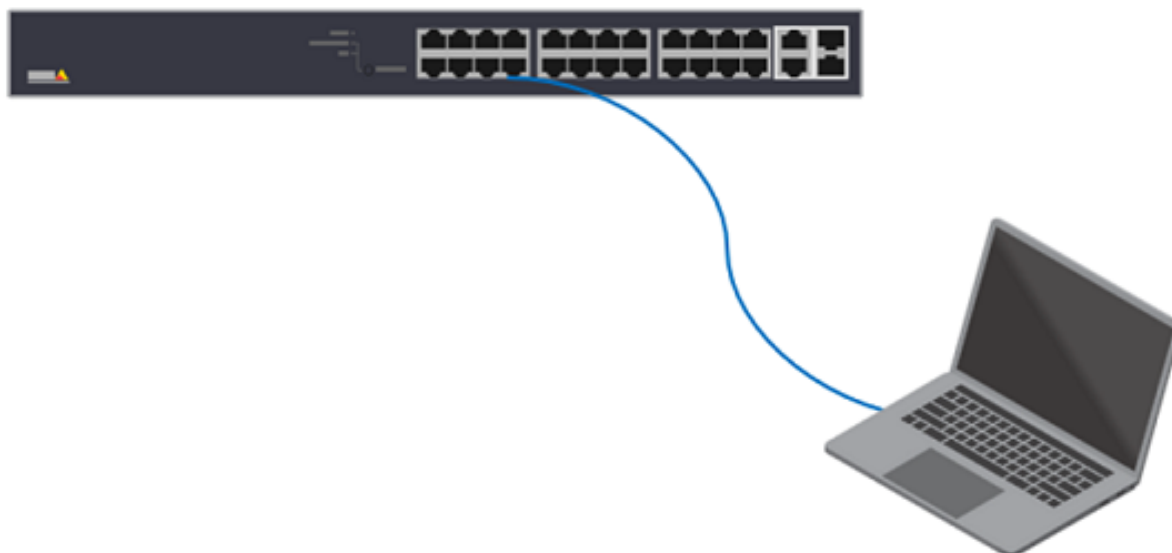

Accessing the web interface is the easiest way to configure settings or make changes to an Axis Network Switch. The web interface can also give access to a non-Administrator account allowing the user to view the configurations but not allowing any changes.

1. Power on the switch. Connecting the PC to any Ethernet ports on the switch via an ethernet cable.
2. By default, the switch will get the IP address from the DHCP server. However, if the DHCP server is not available, it will fallback to 192.168.0.254/24. You can also use *AXIS IP Utility* or *AXIS Device Manager* to find the product on the network.
3. Open a browser on your PC. Enter the IP in the address bar and press "Enter".
4. The default username and password are on the product label.
5. Follow the steps in the setup wizard to:
 - Change the password (recommended for security reasons)
 - Set the IP address via DHCP or manually
 - Configure the DHCP server
 - Set the date & time information
 - Set the system information
6. Click Apply.
7. Re-login using the new password.

Access via SSH

SSH is disabled by default so the users have to log into the webpage to enable it first. To enable it via the web interface:

1. Choose Advanced > Security > Configuration > Switch > Auth Method > ssh.
2. Click the dropdown list. Select local.

Authentication Method					
Client		Methods		Service Port	Fallback
console	local	no	no		<input type="checkbox"/>
ssh	local	no	no	22	<input type="checkbox"/>
http	local	no	no	80	<input type="checkbox"/>
https	local	no	no	443	<input type="checkbox"/>

3. Click Apply.
4. Click save configurations.

Below is an example to log into the switch via ssh:

```
C:\>ssh psadmin@192.168.0.20psadmin@192.168.0.20's password:AXIS T85 SW#
```

Access via the Console port (T8504-R and D8208-R)

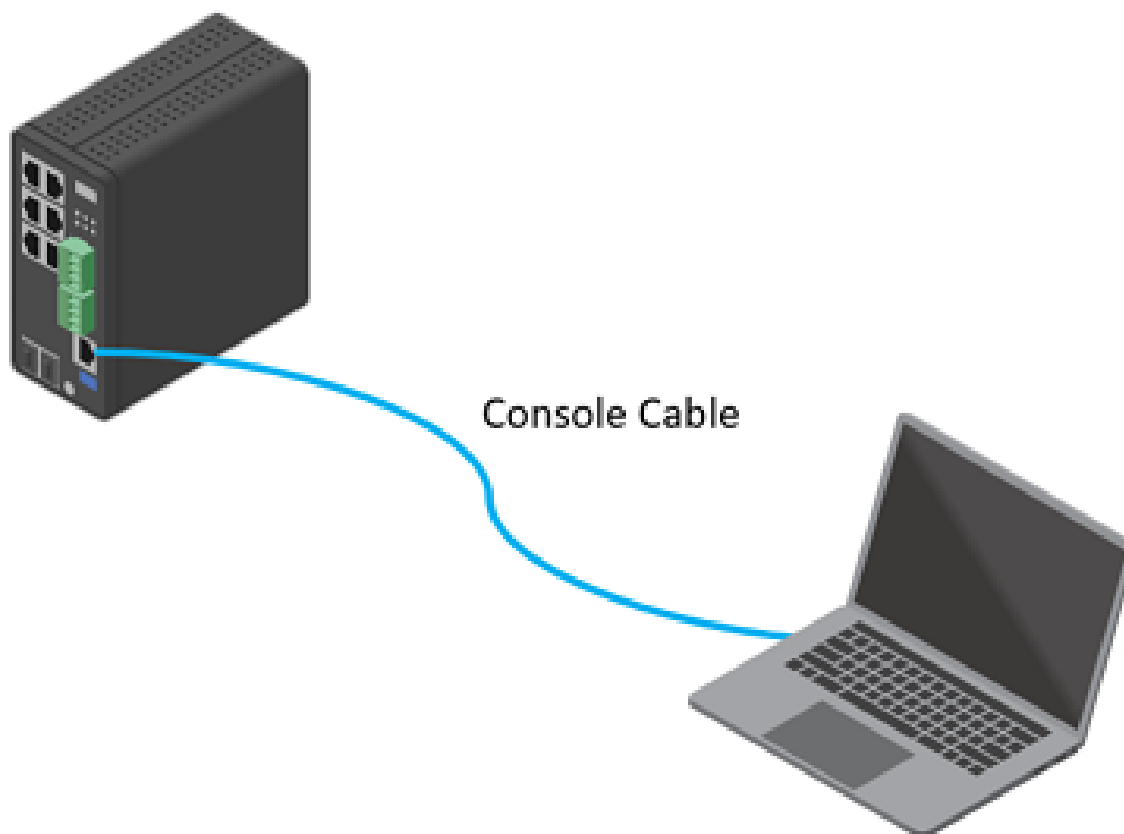

1. Connect a console cable to the console connector on the switch.
2. Connect the other end of the console cable to the COM port on your computer. If your PC doesn't have a COM port, you must use a USB to RS232 adapter.
3. Open a terminal emulator to manage the switch on your computer.
4. Find the correct COM port and use these COM port settings:
 - Baud rate: 115200
 - Stop bits: 1

- Data bits: 8
- Parity: N
- Flow control: None

Switch configuration

Date and Time

Manual configuration

Choose Basic > Date & Time > Configuration. Under "Clock Source", select "Use local Settings".

Time Configuration	
Time Configuration	
Clock Source	Use Local Settings ▾
System Date	2023-08-12 03:13:37 (yyyy-mm-dd hh:mm:ss)
Time Zone Configuration	
Time Zone	(GMT+01:00) Amsterdam, Berlin, Bern, Rome, Stockholm, Vienna ▾
Acronym	<input type="text"/> (0 - 16 characters)

NTP configuration

1. Choose Basic Settings > Date & Time > NTP server. Input the address of the NTP server. The unit of the time-sync interval is a minute. If set to 60, once the switch finishes the initial time sync with the NTP server, it will sync again with the NTP server every 60 minutes. If your DHCP server assigns the NTP address, please select "Enable" under "Automatic". Apply the setting.

NTP Configuration

Automatic	Enabled ▾
Server address via DHCP	
NTP Time-Sync Interval	60 ▾
Server 1	192.168.0.2
Server 2	
Server 3	
Server 4	
Server 5	

2. Choose Basic Settings > Date& Time > Configuration > Time Zone Configuration. Please select the correct Time Zone.
3. In Time Configuration, Clock Source, select "Use NTP Server" and Apply.

POE

Connect a 60 W camera (AXIS T8504-R)

1. Choose Basic > Basic Settings > PoE > Power Management.
2. Under PoE Port Configuration in the PoE Mode drop-down menu, select 2-pair.
 - If you want to assign the same mode for all ports, select the mode on the Port row marked with an asterisk (*)

PoE Port Configuration				
Port	PoE Mode	PoE Schedule	Priority	Maximum Power [W]
*	2-pair	<>	<>	60
1	Disabled Enabled 2-pair	Disabled	Low	60
2				

- If you want to assign the mode for certain ports only, select the mode for selected ports on the respective Port number rows.

PoE Port Configuration				
Port	PoE Mode	PoE Schedule	Priority	Maximum Power [W]
*	Enabled	<>	<>	60
1	Enabled	Disabled	Low	60
2	Disabled Enabled 2-pair	Disabled	Low	60
3	Enabled	Disabled	Low	60

3. Click Apply to save the configuration.

Set a POE Schedule

If you have a certain time frame where you want the switch to provide PoE, for example, to your cameras, it can be useful to create a PoE schedule and assign it to one or more PoE ports. You can create up to 16 PoE schedule profiles. To create a PoE schedule:

1. Choose Advanced > PoE > Configuration > Schedule Profile.
2. In the Profile drop-down menu, select a number for the profile.
3. Change the default profile name as needed.
4. To specify when you want PoE to switch on, select hours (HH) and minutes (MM) in the Start Time drop-down menu.
5. To specify when you want PoE to switch on, select hours (HH) and minutes (MM) in the Start Time drop-down menu.
 - If you want to use the same schedule for all days of the week, select the start and end times on the Week Day row marked with an asterisk (*).
 - If you want to use the same schedule for certain days of the week only, select the start and end times for selected days on the respective Week Day rows.
6. Click Apply to save the configuration.

To assign the created PoE schedule to one or more PoE ports:

1. Go to Basic > Basic Settings > PoE > Power Management.
2. Under PoE Port Configuration in the PoE Schedule drop-down menu, select the number of the specified PoE schedule profile.
 - If you want to assign the same profile for all ports, select the profile number on the Port row marked with an asterisk (*).
 - If you want to assign the same profile for certain ports only, select the profile numbers for selected ports on the respective Port number rows.
3. Click Apply to save the settings.

Port Configuration

Speed and duplex

It is critical to properly configure both speed and duplex on the network interface for a reliable network connection. A common issue is the mismatch of speed and duplex on the Interfaces.

When the switches connect with other devices, we recommend that both interfaces on the link should have the same settings.

To change the speed and duplex settings of the switch ports. Choose Advanced > Ports > Configuration.

Ports Configuration Home > Ports > Configuration

Port	Link	Speed		Adv Duplex		Adv speed			Flow Control			Maximum Frame Size	Frame Length Check
		Current	Configured	Fdx	Hdx	10M	100M	1G	Enable	Current Rx	Current Tx		
*			<>	<input checked="" type="checkbox"/>	<input checked="" type="checkbox"/>	<input checked="" type="checkbox"/>	<input checked="" type="checkbox"/>	<input checked="" type="checkbox"/>	<input type="checkbox"/>			9600	<input type="checkbox"/>
1	●	1Gfdx	Auto	<input checked="" type="checkbox"/>	<input checked="" type="checkbox"/>	<input checked="" type="checkbox"/>	<input checked="" type="checkbox"/>	<input checked="" type="checkbox"/>	<input type="checkbox"/>	<input checked="" type="checkbox"/>	<input checked="" type="checkbox"/>	9600	<input type="checkbox"/>
2	●	Down	Auto	<input checked="" type="checkbox"/>	<input checked="" type="checkbox"/>	<input checked="" type="checkbox"/>	<input checked="" type="checkbox"/>	<input checked="" type="checkbox"/>	<input type="checkbox"/>	<input checked="" type="checkbox"/>	<input checked="" type="checkbox"/>	9600	<input type="checkbox"/>
3	●	Down	Auto	<input checked="" type="checkbox"/>	<input checked="" type="checkbox"/>	<input checked="" type="checkbox"/>	<input checked="" type="checkbox"/>	<input checked="" type="checkbox"/>	<input type="checkbox"/>	<input checked="" type="checkbox"/>	<input checked="" type="checkbox"/>	9600	<input type="checkbox"/>

In the example below, both devices' network interfaces are configured to "Auto-Negotiation". The link is 1000M/ full duplex after successful negotiation.

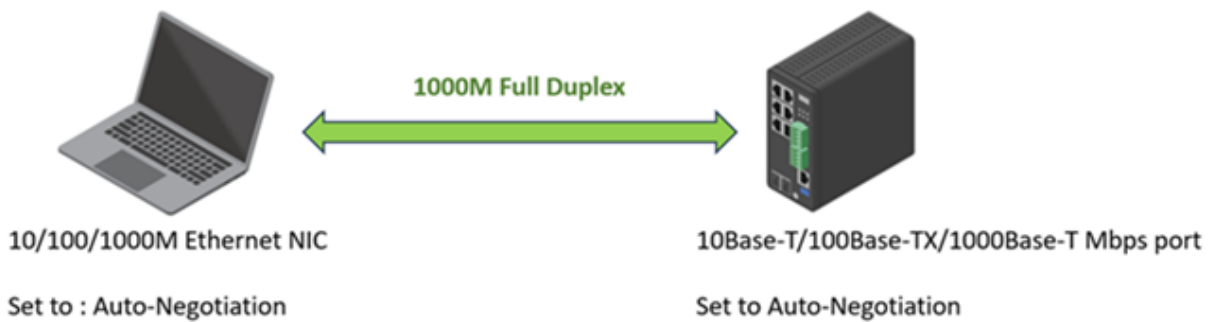

However, you may need to specify the speed and duplex mode under certain scenarios manually:

- When the peer device does not support the Auto-Negotiation function
- the device cannot be connected after configuring to use the Auto-Negotiation
- the interface has a large number of wrong packets or packet loss

SFP

When an SFP module is connected to the switch, you can check the SFP module information by Choose Advanced > Ports > Status > SFP Port info.

Home > Ports > Status > SFP Port Info

Auto-refresh  Port 7 ▾

Connector Type	SFP or SFP Plus - Reserved
Fiber Type	Copper
Tx Central Wavelength	0
Bit Rate	1000 Mbps
Vendor OUI	ac-cc-8e
Vendor Name	AxisComm
Vendor P/N	5801-821-01
Vendor Revision	1
Vendor Serial Number	NB19130000149
Date Code	190329
Temperature	none
Vcc	none
Mon1 (Bias)	none
Mon2 (TX PWR)	none
Mon3 (RX PWR)	none

In order to ensure proper operation of Axis products with SFP support, it is recommended that all Axis supported SFP devices utilize Axis SFP transceivers which have been fully tested for consistent behavior in Axis SFP supported devices. Due to varying performance of third-party SFP transceivers, use would be at own risk and may result in limited network performance and/or no connection at all. Axis can only guarantee full support for Axis supplied SFP transceiver modules.

VLAN

VLANS are typically used on large networks to create multiple broadcast domains, but they can also be used to segregate network traffic. For example, video traffic can be part of one VLAN, and other network traffic can be part of another.

Create VLANs

In the below example, we create additional 2 VLANs, VLAN 10 and VLAN 20. And create trunk ports on both Switches.

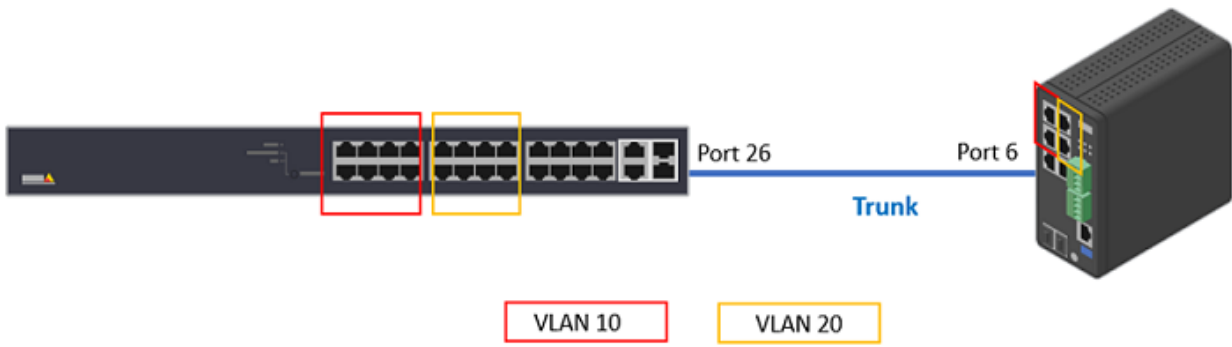

1. Choose Advanced > VLANs > Configurations.
2. Under "Allowed Access VLANs", enter the VLANs you want to create.

VLAN Configuration

Global VLAN Configuration

Allowed Access VLANs	<input type="text" value="1, 20, 30"/>	(e.g. 1,2,10-13,15)
Ethertype for Custom S-ports	<input type="text" value="88A8"/>	

3. To assign a created VLAN ID to a given port under Port VLAN Configuration, enter the ID to the Port VLAN field.

Port VLAN Configuration

Port	Mode	Port VLAN	Port Type	Ingress Filtering
*	<input type="text" value="<>"/>	<input type="text" value="1"/>	<input type="text" value="<>"/>	<input checked="" type="checkbox"/>
1	Access	<input type="text" value="20"/>	C-Port	<input type="checkbox"/>
2	Access	<input type="text" value="20"/>	C-Port	<input type="checkbox"/>
3	Access	<input type="text" value="20"/>	C-Port	<input type="checkbox"/>

4. To Configure a port as Trunk Port. In the dropdown list of "Mode", select "Trunk". Make sure the "Allowed VLANs" field is correct.

Port VLAN Configuration

Port	Mode	Port VLAN	Port Type	Ingress Filtering	Ingress Acceptance	Egress Tagging	Allowed VLANs
*	<input type="text" value="<>"/>	<input type="text" value="1"/>	<input type="text" value="<>"/>	<input checked="" type="checkbox"/>	<input type="text" value="<>"/>	<input type="text" value="<>"/>	<input type="text" value="1"/>
1	Trunk	<input type="text" value="1"/>	C-Port	<input type="checkbox"/>	Tagged and Untagged	Untag Port VLAN	<input type="text" value="1-4095"/>

5. Click Apply to save the settings.
6. Do the same configurations on the other switch.

Inter VLAN routing via AXIS Switch

Access the cameras in different VLANs. If you don't have a router in your network, you can enable the Router mode in the AXIS Switches.

1. Choose Advanced > System > Configuration > IP. Under "Mode", select "Router".

IP Configuration	
Mode	Router
DNS Server	No DNS server
DNS Proxy	<input type="checkbox"/>

2. In the same page, make sure all the VLAN interfaces have been configured.

Delete	VLAN	IPv4 DHCP			IPv4	
		Enable	Fallback	Current Lease	Address	Mask Length
<input type="checkbox"/>	1	<input type="checkbox"/>	0		192.168.0.101	24
<input type="checkbox"/>	20	<input type="checkbox"/>	0		192.168.2.1	24
<input type="checkbox"/>	30	<input type="checkbox"/>	0		192.168.3.1	24

Add Interface

3. Set the Gateway for the devices.
 - Cameras in VLAN 20, gateway: 192.168.2.1
 - Cameras in VLAN 30, gateway: 192.168.3.1
 - PC is in VLAN 1, gateway: 192.168.0.101
4. Use Ping to test the connectivity between VLANs. In this example, the IP of the PC is 192.168.0.102 which sits in VLAN 1. From this PC, we open a browser and issue a VAPIX command to camera (192.168.2.10) in VLAN 20 to Ping another camera (192.168.3.11) in VLAN 30.

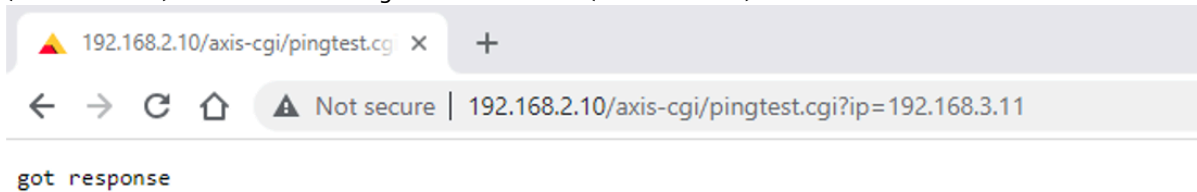

```

C:\> Windows IP Configuration

Ethernet adapter Ethernet:

    Connection-specific DNS Suffix  . : 
    Link-local IPv6 Address . . . . . : fe80::bdb2:adb3:cf5d:ad76%25
    IPv4 Address. . . . . : 192.168.0.102
    Subnet Mask . . . . . : 255.255.255.0
    Default Gateway . . . . . : 192.168.0.101
    
```

Spanning Tree Protocol

When deploying Layer 2 network, redundant paths are normally configured. Although a redundant path can protect against single-point failure, it can also lead to a loop and eventually cause a network broadcast storm.

Spanning Tree Protocol(STP) is designed to prevent loops on Layer 2 networks when a redundant link exists. The common STP protocols are

- The original STP, defined in IEEE 802.1D
- Rapid STP or RSTP, defined in IEEE 802.1w. It is an improved STP version with a faster convergence time when link failure happens.
- Multiple STP or MSTP, defined in IEEE 802.1s. It can group multiple VLANs into a spanning tree instance and create multiple instances. In addition to that, it also provides load balancing when separating the instances into different paths on the network.

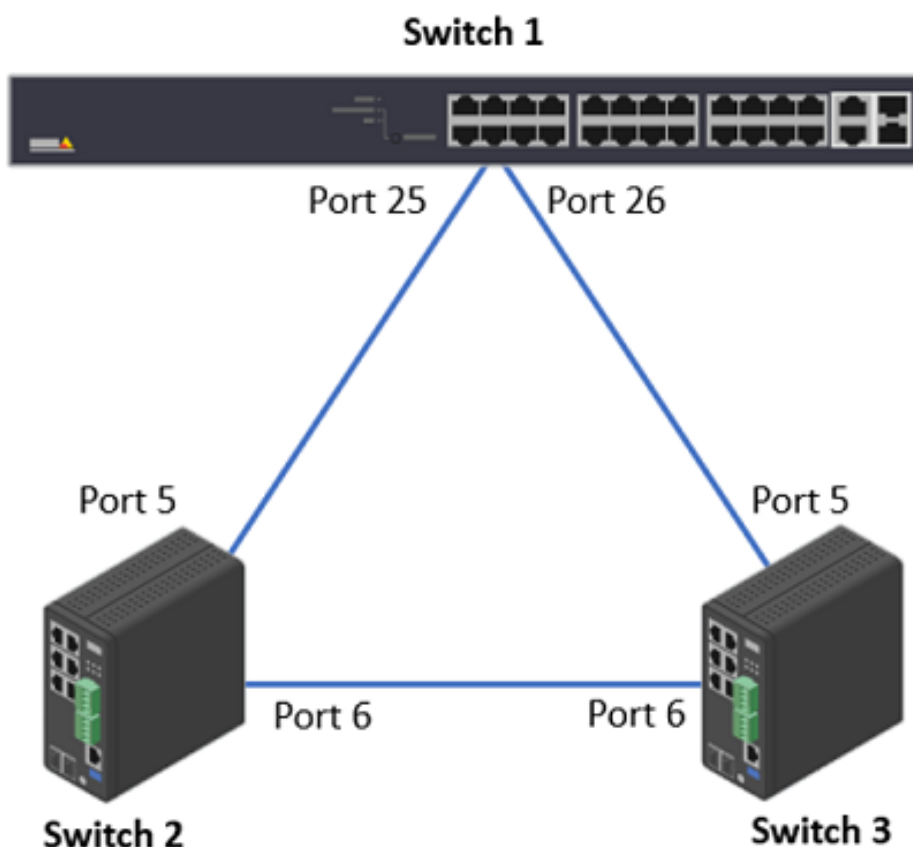

STP

1. Choose **Advanced > Spanning Tree > Configuration > Bridge Settings > Basic Settings > Protocol Version**. In the dropdown menu, select **STP**.

STP Bridge Configuration

Basic Settings	
Protocol Version	STP ▾
Bridge Priority	STP RSTP MSTP
Hello Time	2
Forward Delay	15
Max Age	20
Maximum Hop Count	20
Transmit Hold Count	6

2. Click Apply to save the settings.
3. Choose Advanced > Spanning Tree > Configuration > CIST Ports > CIST Normal Port Configuration. Make sure that "STP Enabled" is selected for the switches' ports as follows:
 - Switch 1: Port 25 and Port 26
 - Switch 2: Port 5 and Port 6
 - Switch 3: Port 5 and Port 6
4. Click Apply to save the settings.
5. Check the port status. Choose Advanced > Spanning Tree > Status > Port Status.
 - Switch 1: Port 25 (Discarding), Port 26 (Forwarding)
 - Switch 2: Port 5 (Forwarding), Port 6 (Forwarding)
 - Switch 3: Port 5 (Forwarding), Port 6 (Forwarding)

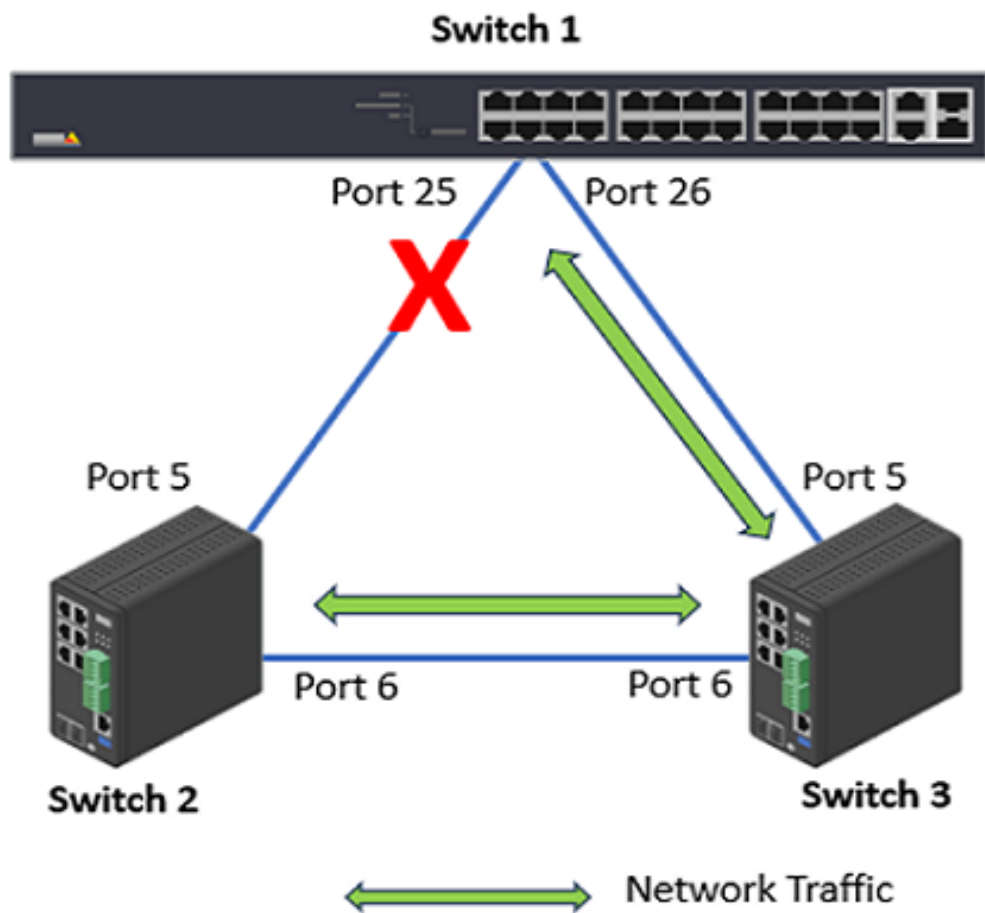

6. Now let's remove the network cable between Switch 2 and Switch 3.
7. Check the port status. Choose Advanced > Spanning Tree > Status > Port Status.
 - Switch 1: Port 25 (Forwarding), Port 26 (Forwarding)
 - Switch 2: Port 5 (Forwarding), Port 6 (Discarding)
 - Switch 3: Port 5 (Forwarding), Port 6 (Discarding)

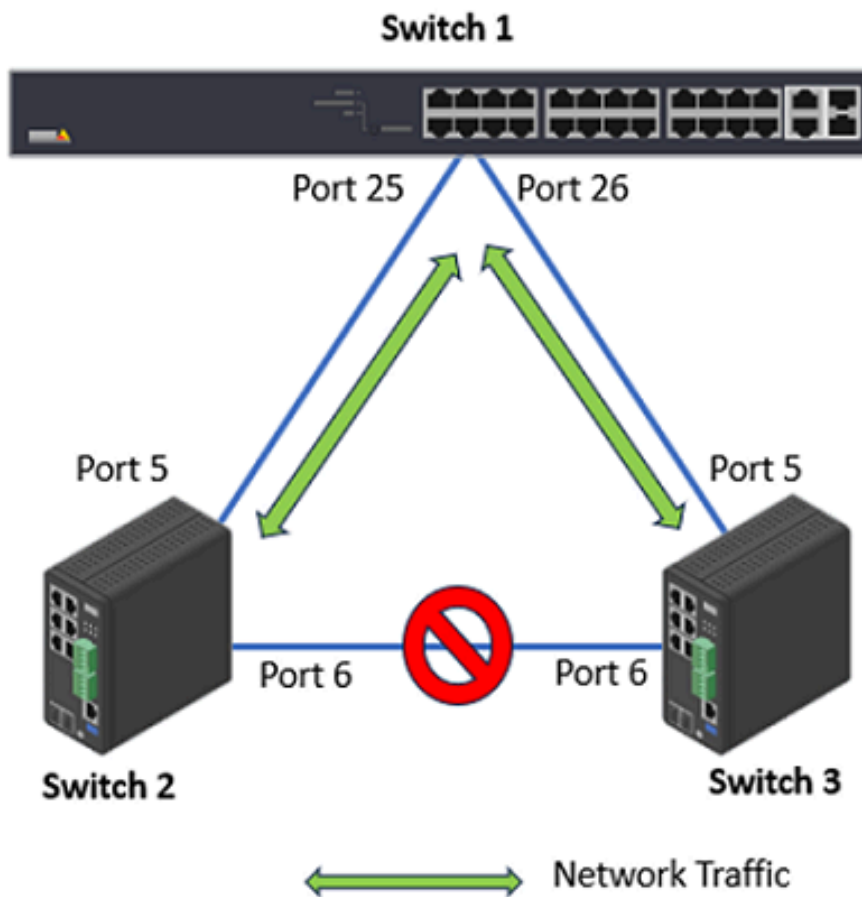

RSTP

In this example, RSTP is used as the STP protocol. And we make the Switch 1 as the root switch so that no ports on it will be in Discarding status.

1. Choose Advanced > Spanning Tree > Configuration > Bridge Settings > Basic Settings > Protocol Version. In the dropdown menu, select "RSTP".
2. To make Switch 1 become the root bridge, we lower the "Bridge Priority" to 28672.

STP Bridge Configuration

Basic Settings	
Protocol Version	RSTP ▼
Bridge Priority	28672 ▼
Forward Delay	15
Max Age	20
Maximum Hop Count	20
Transmit Hold Count	6

3. Click Apply to save the setting.
4. On both Switch 2 and Switch 3, change the Protocol Version to "RTSP". Click Apply to save the settings.
5. Choose Advanced > Spanning Tree > Configuration > CIST Ports > CIST Normal Port Configuration. Make sure that "STP Enabled" is selected for the switches' ports as follows:
 - Switch 1: Port 25 and Port 26
 - Switch 2: Port 5 and Port 6
 - Switch 3: Port 5 and Port 6
6. To check the STP status. Choose Advanced > Spanning Tree > Status > Bridge Status. Click "CIST". We can see that Switch 1 is the Root Bridge. And on Switch 3, Port 6 is in Discarding State.

Bridge Instance	CIST
Bridge ID	32768.AC-CC-8E-D7-0F-3E
Root ID	28672.AC-CC-8E-E7-65-79
Root Cost	20000
Root Port	5
Regional Root	32768.AC-CC-8E-D7-0F-3E
Internal Root Cost	0
Topology Flag	Steady
Topology Change Count	110
Topology Change Last	0d 00:15:46

CIST Ports & Aggregations State							
Port	Port ID	Role	State	Path Cost	Edge	Point-to-Point	Uptime
5	128:005	RootPort	Forwarding	20000	No	Yes	0d 02:44:29
6	128:006	AlternatePort	Discarding	20000	No	Yes	0d 02:44:29

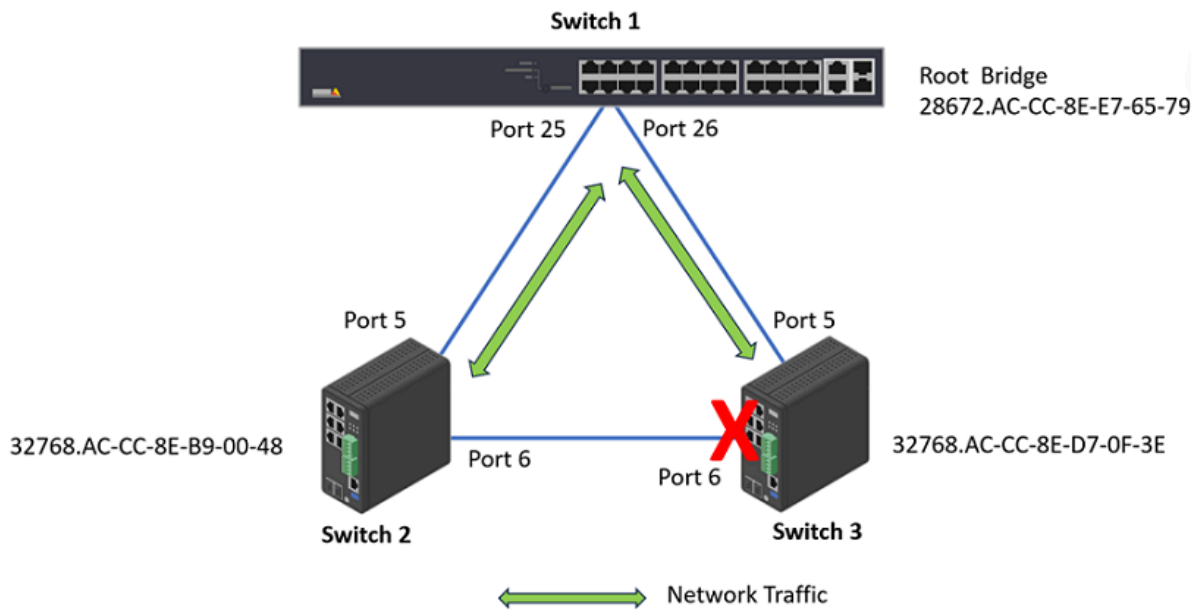

Rapid Ring

The Rapid Ring is a redundancy protocol that used to recover the network from critical link failure. Meanwhile, it can protect the network from loops. Comparing with the Spanning Tree Protocol defined by IEEE, Rapid Ring is much faster.

The Rapid Ring is only available in the Industrial Switches (T8504-R and D8208-R). It supports several different applications, for example, Single Ring, Ring to Ring.

Important

Only one redundant protocol can be used at the same time, before you want to use Rapid Ring, you have to disable the Spanning Tree.

The Single Ring is the most common ring to use. To configure Single Ring, one of the switches must be the "Master role" and the rest switches must be "Member role". Only one switch can be the master role.

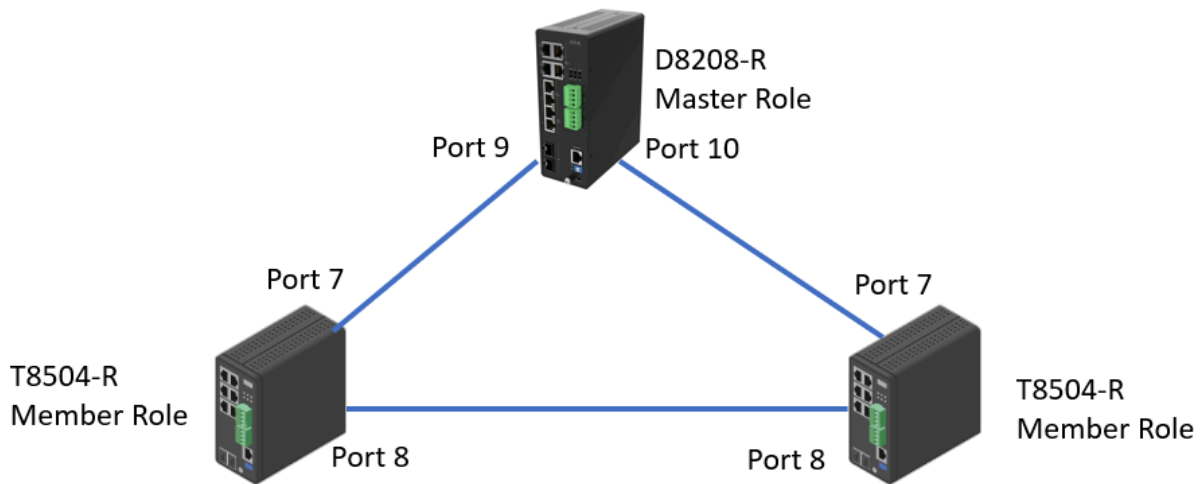

The Rapid Ring configuration is not available in the web interface on T8504-R. To configure it, we need to do it via the command line. In this example, the two T8504-R switches are members.

```
AXIS T85 SW # configure terminal
AXIS T85 SW (config)# rapid-ring entry 1 role member port1
GigabitEthernet 1/7 port2 GigabitEthernet 1/8
```

To configure Rapid Ring on D8208-R

1. Choose Advanced > Rapid Ring.
2. Select "Master" as the role and select the 2 ports respectively.

Global Configuration				
Role	1st Ring Port	Status	2nd Ring Port	Status
Master	Port 9	Forwarding	Port 10	Discarding
Disabled	Port 1	Forwarding	Port 1	Forwarding

3. Click "Apply" to save the configuration.

To verify the configuration, we can check the port Status. In this example, port 9 is "Forwarding" and Port 10 is "Discarding". If the switch is a Master role, by default 1st Ring Port will be the active path and 2nd Ring Port as backup path.

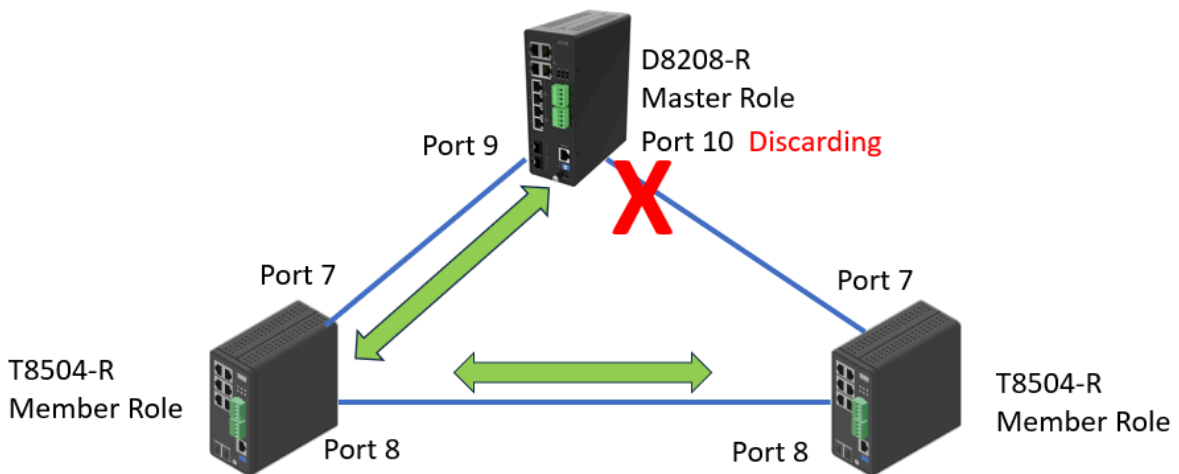

Now we disconnect the link between the two T8504-R switches. From D8208-R, we can see both port 9 and 10 are now in "Forwarding" status.

Global Configuration				
Role	1st Ring Port	Status	2nd Ring Port	Status
Master	Port 9	Forwarding	Port 10	Forwarding
Disabled	Port 1	Forwarding	Port 1	Forwarding

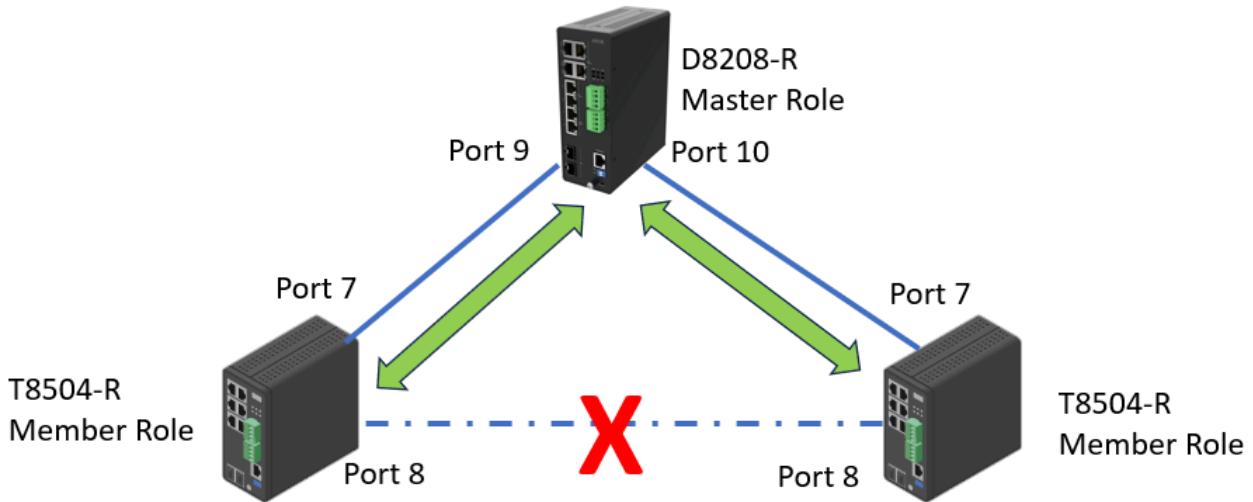

To show the Rapid Ring Status on the T8504-R switch, please use the below command:

```
AXIS T85 SW # show rapid-ringEntry Index : 1Rapid Ring Role : MemberRapid Ring Port 1 : 7Rapid Ring Port 2 : 8Rapid Ring Port 1 State : ForwardingRapid Ring Port 2 State : DiscardingEntry Index : 2Rapid Ring Role : DisabledRapid Ring Port 1 : 1Rapid Ring Port 2 : 1Rapid Ring Port 1 State : ForwardingRapid Ring Port 2 State : ForwardingRing-to-Ring Role : DisabledRing-to-Ring Port : 1Ring-to-Ring Port State : Forwarding
```

The industrial switches come with the DIP Switch. Please keep both "RM" and "RC" in "ON" state which is also the default state. Otherwise, all Rapid Ring, Spanning Tree software configurations via web interface and command line are deactivated.

Ethernet Channels

Ethernet channel, also known as Link Aggregation Control Protocol(LACP), is a technique used to bundle multiple physical switch ports between two switches into one logical port.

There are several advantages of doing this:

- Increased bandwidth. In the example, port 25 and 26 speed is 1Gbit/s. After bundling, the total bandwidth between Switch 1 and Switch 2 will be 2Gbits/s.
- Load balancing. The traffic between Switch 1 and Switch 2 will be distributed through the 2 links.
- Redundancy. If one physical link is down, the Ethernet Channel will still work on the remaining link.

Important

Please don't connect multiple network cables between the two switches before proper configurations to avoid loop. Only full-duplex ports can join an aggregation and ports must be in the same speed in each group.

Static Ethernet Channel

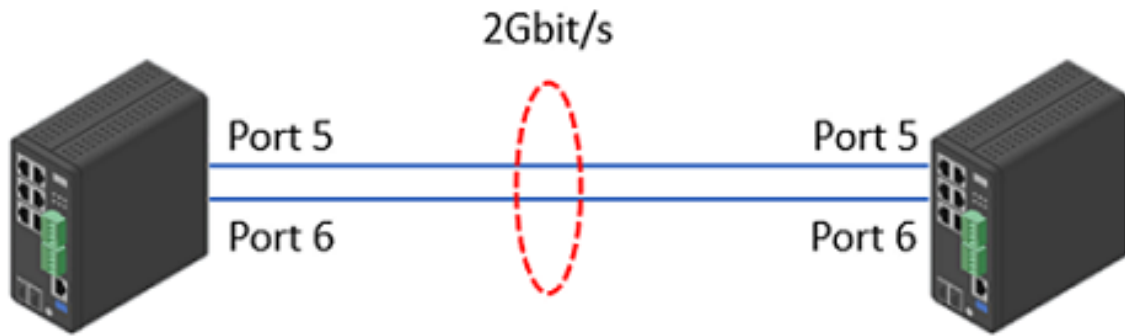

1. Choose Advanced > Aggregation > Configuration > Static > Aggregation Group Configuration. In this example, we put both ports 5 & 6 into Group 1.

Aggregation Group Configuration

Group ID	Port Members							
	1	2	3	4	5	6	7	8
Normal	<input checked="" type="checkbox"/>	<input checked="" type="checkbox"/>	<input checked="" type="checkbox"/>	<input checked="" type="checkbox"/>	<input type="checkbox"/>	<input type="checkbox"/>	<input checked="" type="checkbox"/>	<input checked="" type="checkbox"/>
1	<input type="checkbox"/>	<input type="checkbox"/>	<input type="checkbox"/>	<input type="checkbox"/>	<input checked="" type="checkbox"/>	<input checked="" type="checkbox"/>	<input type="checkbox"/>	<input type="checkbox"/>
2	<input type="checkbox"/>	<input type="checkbox"/>	<input type="checkbox"/>	<input type="checkbox"/>	<input type="checkbox"/>	<input type="checkbox"/>	<input type="checkbox"/>	<input type="checkbox"/>
3	<input type="checkbox"/>	<input type="checkbox"/>	<input type="checkbox"/>	<input type="checkbox"/>	<input type="checkbox"/>	<input type="checkbox"/>	<input type="checkbox"/>	<input type="checkbox"/>
4	<input type="checkbox"/>	<input type="checkbox"/>	<input type="checkbox"/>	<input type="checkbox"/>	<input type="checkbox"/>	<input type="checkbox"/>	<input type="checkbox"/>	<input type="checkbox"/>

Apply Reset

2. Click Apply to save the settings.
3. Do the same setup on the other switch.
4. Verify the status. Choose Advanced > Aggregation > Status > Aggregation. The "Type" is Static.

Aggregation Status Home > Aggregation > Status > Aggregation

Auto-refresh

Aggregation Status						
Aggr ID	Name	Type	Speed	Configured Ports	Aggregated Ports	Aggregated Bandwidth
1	LLAG1	Static	1G	GigabitEthernet 1/5-6	GigabitEthernet 1/5-6	2G

LACP

1. Choose Advanced > Aggregation > Configuration > LACP, In this example, we select both ports 5 and 6.

LACP Port Configuration Home > Aggregation > Configuration > LACP

Port	LACP Enabled	Key	Role	Timeout	Prio
*	<input type="checkbox"/>	<> <input type="text"/>	<> <input type="text"/>	<> <input type="text"/>	<input type="text" value="32768"/>
1	<input type="checkbox"/>	Auto <input type="text"/>	Active <input type="text"/>	Fast <input type="text"/>	<input type="text" value="32768"/>
2	<input type="checkbox"/>	Auto <input type="text"/>	Active <input type="text"/>	Fast <input type="text"/>	<input type="text" value="32768"/>
3	<input type="checkbox"/>	Auto <input type="text"/>	Active <input type="text"/>	Fast <input type="text"/>	<input type="text" value="32768"/>
4	<input type="checkbox"/>	Auto <input type="text"/>	Active <input type="text"/>	Fast <input type="text"/>	<input type="text" value="32768"/>
5	<input checked="" type="checkbox"/>	Auto <input type="text"/>	Active <input type="text"/>	Fast <input type="text"/>	<input type="text" value="32768"/>
6	<input checked="" type="checkbox"/>	Auto <input type="text"/>	Active <input type="text"/>	Fast <input type="text"/>	<input type="text" value="32768"/>
7	<input type="checkbox"/>	Auto <input type="text"/>	Active <input type="text"/>	Fast <input type="text"/>	<input type="text" value="32768"/>
8	<input type="checkbox"/>	Auto <input type="text"/>	Active <input type="text"/>	Fast <input type="text"/>	<input type="text" value="32768"/>

2. Click Apply to save the settings.
3. Do the same settings on the other switch.
4. Verify the status. Choose Advanced > Aggregation > Status > LACP > System Status.

LACP System Status Home > Aggregation > Status > LACP > System Status

Auto-refresh

Aggr ID	Name	Partner System ID	Partner Key	Partner Prio	Last Changed	Local Ports
1	LLAG1	ac-cc-8e-b9-00-48	3	32768	0d 00:09:05	5,6

5. You can also see the aggregation status under Advanced > Aggregation > Status > Aggregation. The "Type" is LACP.

Aggregation Status Home > Aggregation > Status > Aggregation

Auto-refresh

Aggregation Status

Aggr ID	Name	Type	Speed	Configured Ports	Aggregated Ports	Aggregated Bandwidth
1	LLAG1	LACP	1G	GigabitEthernet 1/5-6	GigabitEthernet 1/5-6	2G

Access the switch via HTTPS

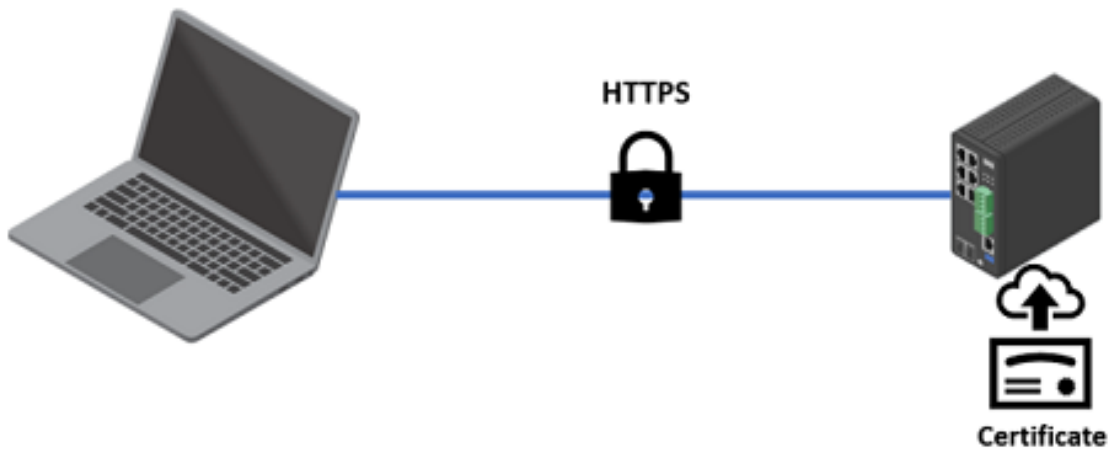

By enabling HTTPS, all the data or administrative tasks you performed on the switch will be encrypted. Make it very difficult for unauthorized users to read the data.

The AXIS Switch supports RSA certificate only. The supported RSA key lengths are 1024 bit, 2048 bit and 4096 bit. However, the 4096 bit key length may affect the performance of the switch.

To upload your own certificate via the Web Browser:

1. Choose Advanced > Security > Configuration > Switch > HTTPS.
2. Select "upload" for "Certificate Maintain". The certificate should be in PEM format.
3. Fill in the Passphrase for the certificate file if your uploaded certificate is protected by a specific passphrase.
4. Select "Web Browser" for the "Certificate upload" method.
5. Under "File Upload", click "Choose File" to select and upload a certificate PEM file into the switch. The file should contain the certificate and private key together. Click "Apply" to save the settings.

HTTPS Configuration Home > Security > Configuration > Switch > HTTPS

Certificate Maintain	Upload ▼
Certificate Pass Phrase	<input type="text"/>
Certificate Upload	Web Browser ▼
File Upload	<input type="button" value="Choose File"/> T85_Switch.pem
Certificate Status	Switch secure HTTP certificate is presented

6. Choose Advanced > Security > Configuration > Switch > Auth Method. Under "Authentication Method", for "https", select "local".
7. When HTTPS is enabled, enable HTTP automatic redirect or disable it on the switch.

Authentication Method Configuration

Authentication Method	
Client	
console	local ▼
ssh	local ▼
http	redirect ▼
https	local ▼

8. Click "Apply" to save the settings.
9. Verify the connection.

The screenshot shows a web browser window with the URL `https://172.25.200.24`. The page displays the Axis Communications logo and the device model `AXIS T8504-R`. The navigation menu is set to `Basic` settings, with options for `Basic Settings`, `System Overview`, `TCP/IP`, `PoE`, and `Date & Time`. A security warning dialog is overlaid on the page, stating: "Connection security for 172.25.200.24. You are securely connected to this site. Verified by: axis. Mozilla does not recognize this certificate issuer. It may have been added from your operating system or by an administrator. Learn more. More information". Below the warning, the system status is displayed:

Connected Devices	33
PoE Power Consumption	0 [W]
Total PoE Available	240 [W]

IEEE 802.1X Configuration

IEEE 802.1X is an IEEE standard for port-based network access control ("port" means the physical connection to the LAN infrastructure). It is part of the IEEE 802.1 group of networking protocols and provides an authentication mechanism for devices to connect to a LAN, either establishing a connection or preventing the connection if authentication fails. For more information, read it at *AXIS OS Lifecycle guide*.

In order to use port-based authentication, the network must be equipped with a RADIUS server and a network switch with support for IEEE 802.1X. The RADIUS server needs to know all the trusted "clients". Where "clients" are the managed switches in this case. You may need to contact the IT Administrator for the information and configuration.

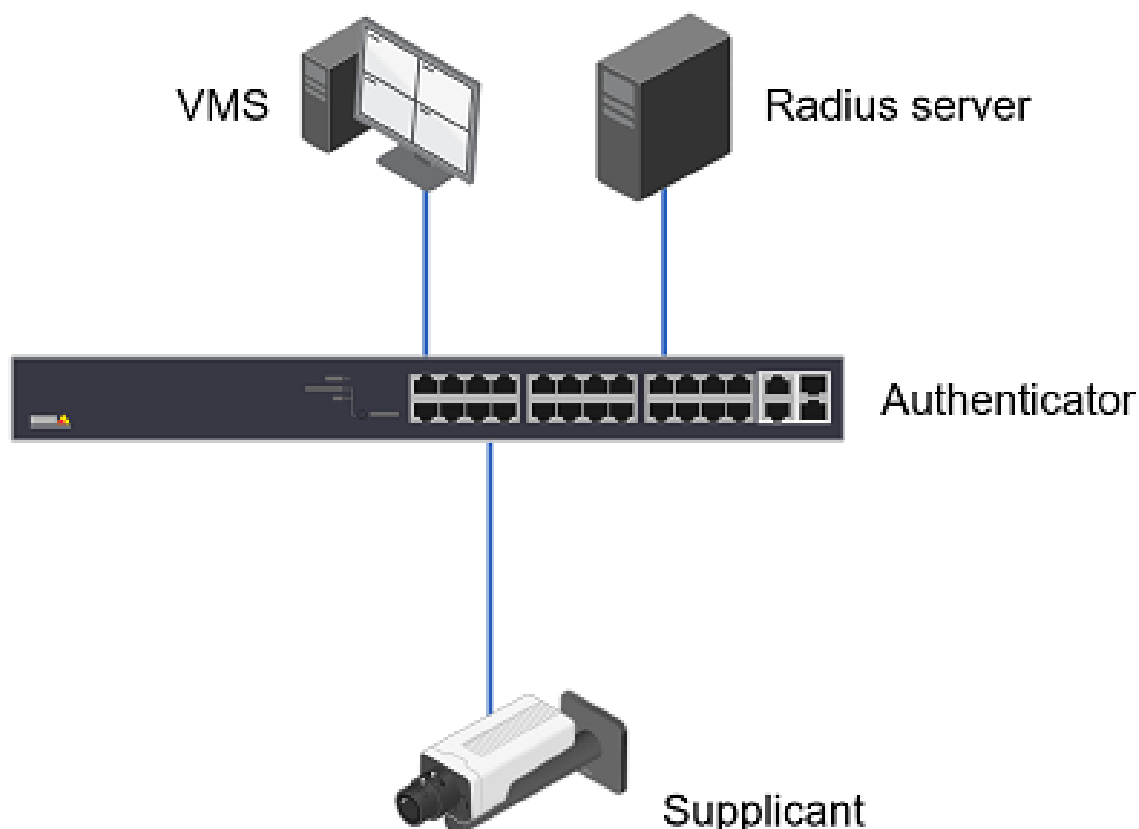

To Configure the feature in AXIS Switches:

1. Disable Spanning Tree Protocol on the port for 802.1x authentication. Choose Advanced > Spanning Tree > Configuration > CIST ports. Uncheck the ports and apply the configuration.
2. Choose Advanced > Security > AAA > RADIUS > Server Configuration. Click "Add New Server". Fill in the IP address or Hostname of the RADIUS server. The default port is 1812. Fill in the Key which is the password for the switch to authenticate against the RADIUS server. Click "Apply" to save the configuration.

Server Configuration						
Delete	Hostname	Auth Port	Acct Port	Timeout	Retransmit	Key
<input type="checkbox"/>	192.168.10.4	1812	1813			password

3. Choose Advanced > Security > Configuration > Network > NAS. Under "System Configuration", Set the "Mode" to Enabled.

IEEE 802.1x

Client certificate

p1375_1

CA certificate

PStrainingRootCA

EAP Identity

B8A44F42B4C6

EAPOL Version

1

2

3

Use IEEE 802.1x

Authorized Save

Access Control List

The access control list is a powerful tool to filter the traffic on the switch. It includes multiple rules in sequential order.

The Axis Switch can only inspect the ingress traffic on the ports. When a frame or a packet arrives at the switch, it will check the frame against the rules in the ACL. The frame/packet will be accepted once it matches a permit rule or dropped soon as it matches a deny rule. If no rule is matched, the switch will accept the packet.

The network administrator can use ACL to protect the network from unwanted network traffic. To configure the ACL, Choose Advanced > Security > Network > ACL > Access Control List. Click the "+" icon.

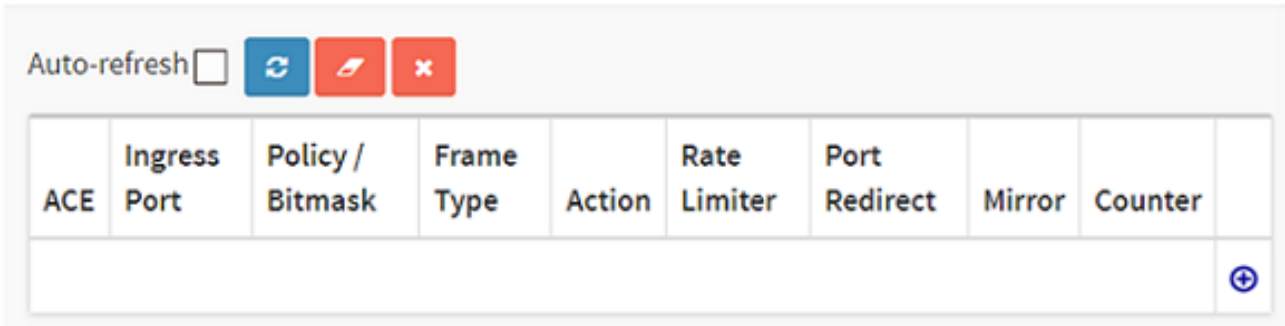

Below are some examples.

Drop the ICMP packets arriving at port 1.

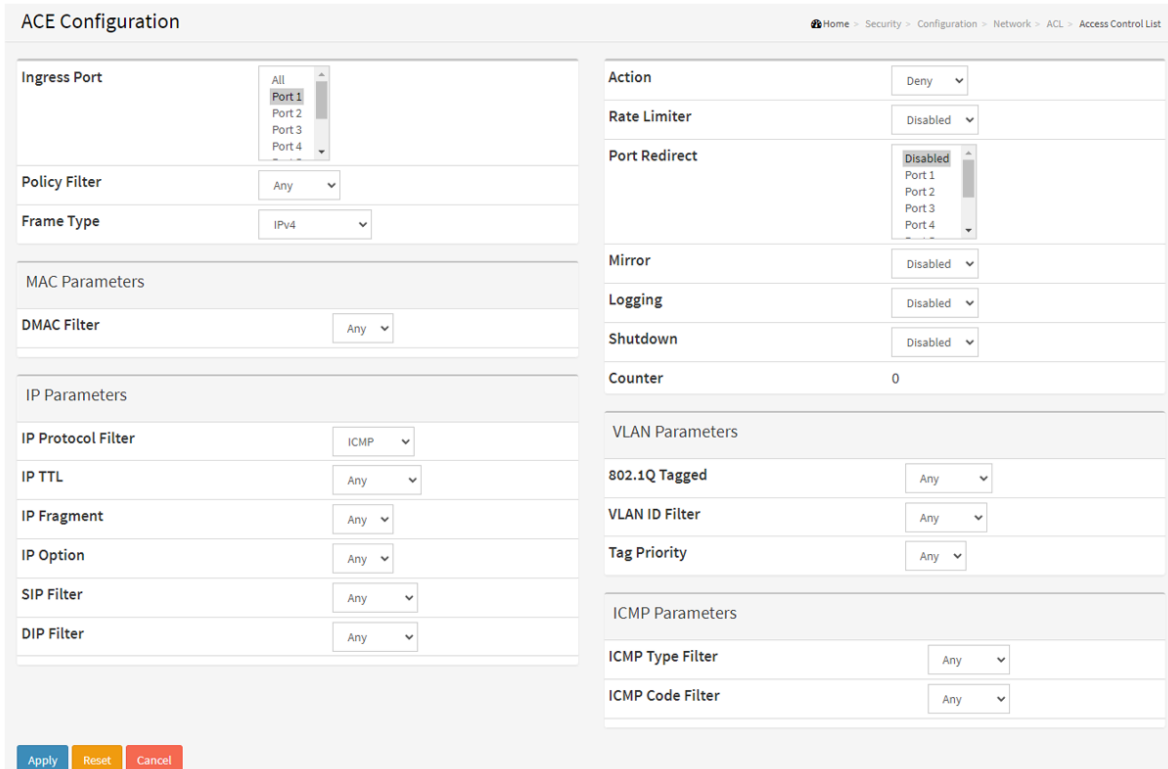

- Ingress port: Port 1
- Frame Type: IPv4
- IP Protocol: ICMP
- Action: Deny







To verify the ACL, we connect a PC to port 1 and ping the camera with 192.168.0.90. The ping fails and the count is 4.

Access Control List Configuration

Home > Security > Configuration > Network > ACL > Access Control List

Auto-refresh   

ACE	Ingress Port	Policy / Bitmask	Frame Type	Action	Rate Limiter	Port Redirect	Mirror	Counter	
1	1	Any	IPv4/ICMP	Deny	Disabled	Disabled	Disabled	4	  
									

```

Command Prompt
C:\Windows\System32>ping 192.168.0.90

Pinging 192.168.0.90 with 32 bytes of data:
Request timed out.
Request timed out.
Request timed out.
Request timed out.

Ping statistics for 192.168.0.90:
    Packets: Sent = 4, Received = 0, Lost = 4 (100% loss),

C:\Windows\System32>
    
```

Drop the broadcast traffic on port 1

- Ingress port: Port 1
- Frame Type: Ethernet Type
- DMAC Filter: BC
- Action: Deny

ACE Configuration

Home > Security > Configuration > Network > ACL > Access Control List

Ingress Port All
Port 1
Port 2
Port 3
Port 4

Policy Filter Any

Frame Type Ethernet Type

MAC Parameters

SMAC Filter Any

DMAC Filter BC

Ethernet Type Parameters

EtherType Filter Any

Action Deny

Rate Limiter Disabled

Port Redirect Disabled
Port 1
Port 2
Port 3
Port 4

Mirror Disabled

Logging Disabled

Shutdown Disabled

Counter 0

VLAN Parameters

802.1Q Tagged Any

VLAN ID Filter Any

Tag Priority Any

Apply Reset Cancel

Drop the ssh traffic arriving port 1

- Ingress port: Port 1
- Frame Type: IPv4

- IP Protocol Filter: TCP
- Dest.Port Filter: Specific

Dest.Port No. 22

The screenshot shows the 'ACE Configuration' page with the following settings:

- Ingress Port:** Port 1
- Policy Filter:** Any
- Frame Type:** IPv4
- MAC Parameters:** DMAC Filter: Any
- IP Parameters:**
 - IP Protocol Filter: TCP
 - IP TTL: Any
 - IP Fragment: Any
 - IP Option: Any
 - SIP Filter: Any
 - DIP Filter: Any
- Action:** Deny
- Rate Limiter:** Disabled
- Port Redirect:** Disabled
- Mirror:** Disabled
- Logging:** Disabled
- Shutdown:** Disabled
- Counter:** 5
- VLAN Parameters:**
 - 802.1Q Tagged: Any
 - VLAN ID Filter: Any
 - Tag Priority: Any
- TCP Parameters:**
 - Source Port Filter: Any
 - Dest. Port Filter: Specific
 - Dest. Port No.: 22
 - TCP FIN: Any
 - TCP SYN: Any
 - TCP RST: Any
 - TCP PSH: Any
 - TCP ACK: Any
 - TCP URG: Any

IGMP Snooping

In the layer 2 network, when a frame is received by the switch port. The switch will learn and save the source MAC address to the MAC address table. Then the switch checks the destination MAC address and lookup the MAC address table to find out which port should forward this frame. If there is no entry in the MAC address table, the switch will normally flood this frame to all the ports except the port that receives the frame.

In a multicast network, the multicast frames have a destination MAC address starting with 01005e. However, this MAC address has never been used as a source MAC address so the switch has never learned about it and saves it into the MAC address table. Due to this, the switch will flood this multicast traffic to all the ports. IGMP snooping helps to suppress the unnecessary flooding of multicast traffic in the layer 2 networks.

When a receiver is interested in receiving multicast traffic, the receiver will send out an IGMP membership report message to the last-hop router. As the name implies, the switch will actively snoop the IGMP packets and use the content in the packets to build a multicast forwarding table. The table includes the multicast groups and the interfaces that the members of each group are connected to. By checking this table, the switch will not forward the multicast traffic to unwanted receivers. Please be aware that IGMP snooping is not a feature of the IGMP protocol.

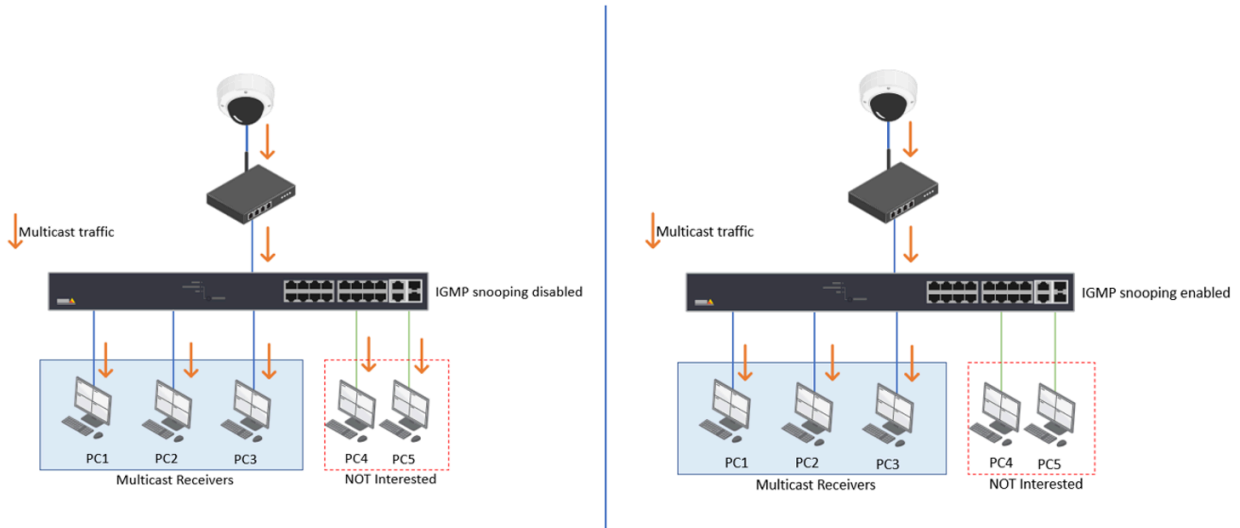

Configure IGMP with a multicast-enabled router

If your network has a multicast-enabled router like the one below, and on the switch, port 1 is connected to the router.

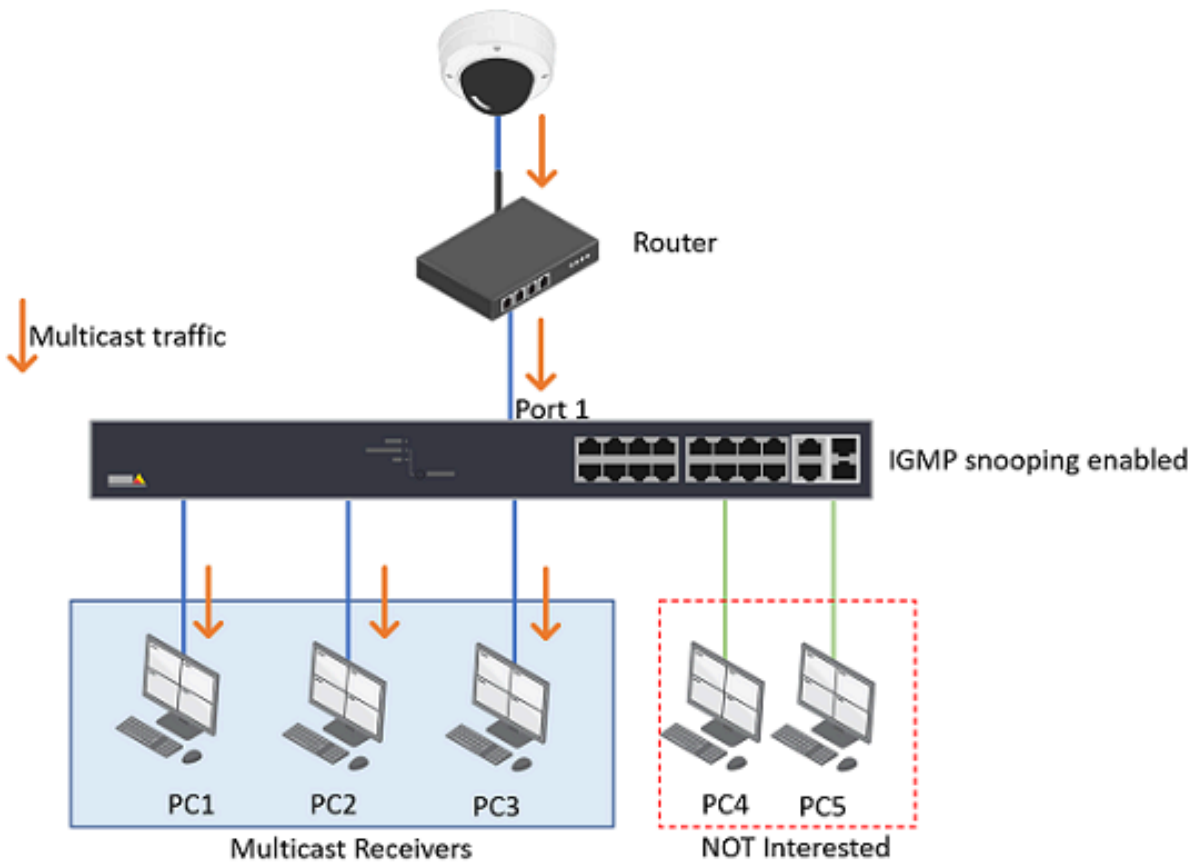

1. Choose Advanced > IPMC > Configuration > IGMP Snooping > Basic Configuration.
 - Check "Snooping Enabled".
 - Uncheck "Unregistered IPMCv4 Flooding Enabled".
 - Under Port Related Configuration, Select Port 1 as the Router Port.

IGMP Snooping Configuration

Global Configuration

Snooping Enabled

Unregistered IPMCv4 Flooding Enabled

IGMP SSM Range 222.0.0.0 / 8

Leave Proxy Enabled

Proxy Enabled

Port Related Configuration

Port	Router Port	Fast Leave	Throttling
*	<input type="checkbox"/>	<input type="checkbox"/>	<>
1	<input checked="" type="checkbox"/>	<input type="checkbox"/>	unlimited
2	<input type="checkbox"/>	<input type="checkbox"/>	unlimited
3	<input type="checkbox"/>	<input type="checkbox"/>	unlimited
4	<input type="checkbox"/>	<input type="checkbox"/>	unlimited
5	<input type="checkbox"/>	<input type="checkbox"/>	unlimited
6	<input type="checkbox"/>	<input type="checkbox"/>	unlimited
7	<input type="checkbox"/>	<input type="checkbox"/>	unlimited
8	<input type="checkbox"/>	<input type="checkbox"/>	unlimited

Apply Reset

2. Click Apply to save the settings.

Configure IGMP in a pure layer 2 environment

If your network only has layer 2 switches without a router.

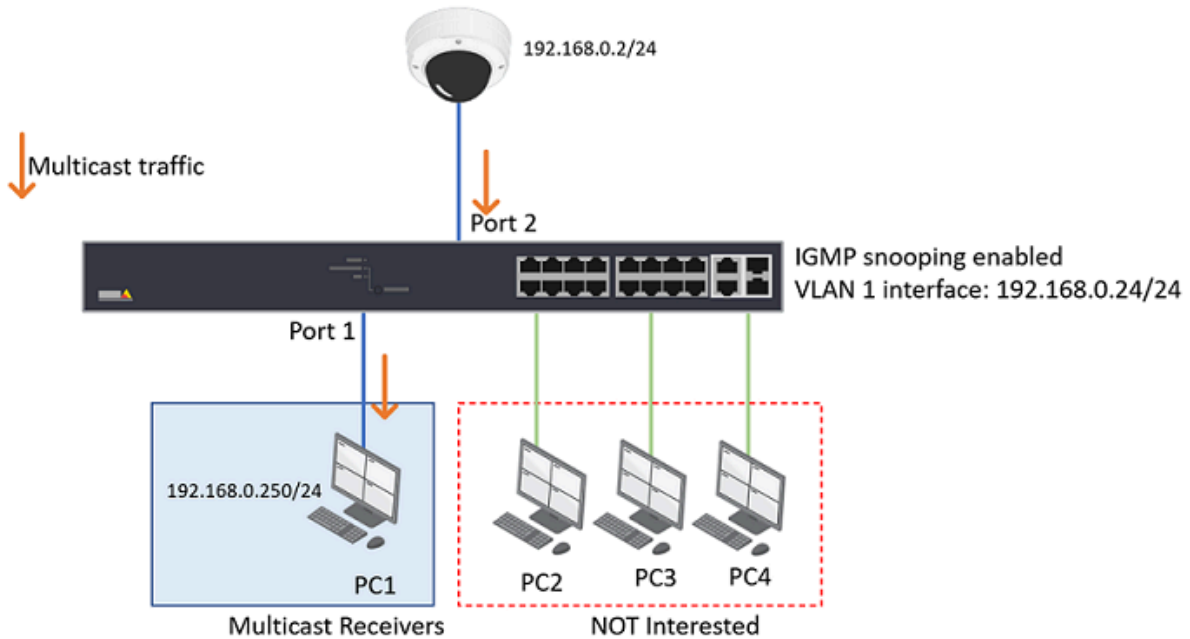

Though a multicast router is more appropriate for multicast handling. Sometimes, the network may not have a router. Then the layer 2 switch will act as an IGMP querier which can fulfill part of that role.

1. Choose Advanced > IPMC > Configuration > IGMP Snooping > Basic Configuration.
 - Check "Snooping Enabled".
 - Uncheck "Unregistered IPMCv4 Flooding Enabled"
2. Choose Advanced > IPMC > Configuration > IGMP Snooping > VLAN Configuration. Click "Add New IGMP VLAN".
3. Fill in the information needed

- VLAN ID: 1 (in this example, all the devices are sitting in VLAN 1)
- Snooping Enabled: check
- Querier Address: 0.0.0.0 (When the Querier address is not set, the system uses IPv4 management address of the IP interface associated with this VLAN, in this example, it will use the VLAN 1 interface IP 192.168.0.24/24)

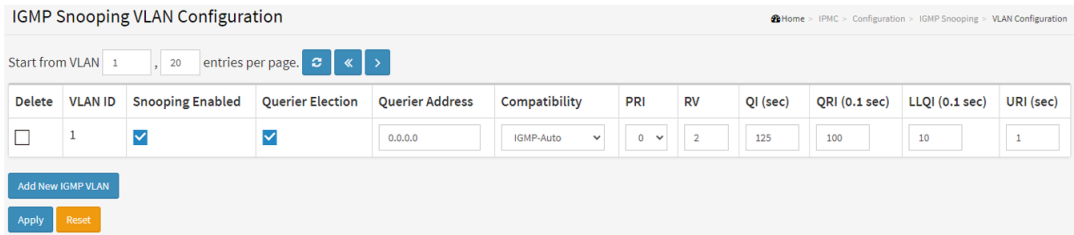

4. From PC1, we use VLC to receive multicast video from the camera. After RTSP negotiation, the multicast address group information is as below:

- Multicast address: 239.198.180.198

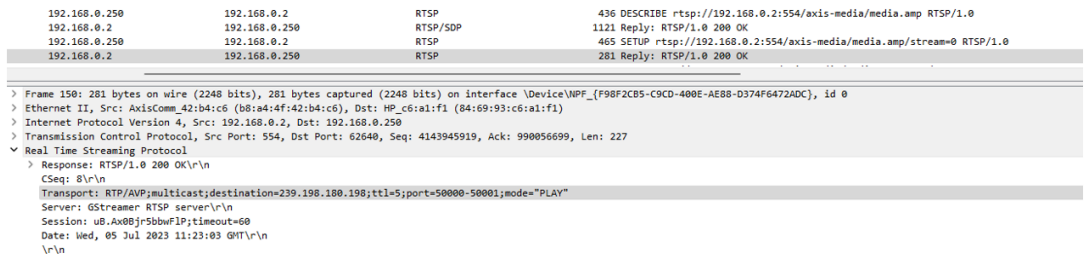

PC 1 sends out IGMP Membership Report to group 239.198.180.198.

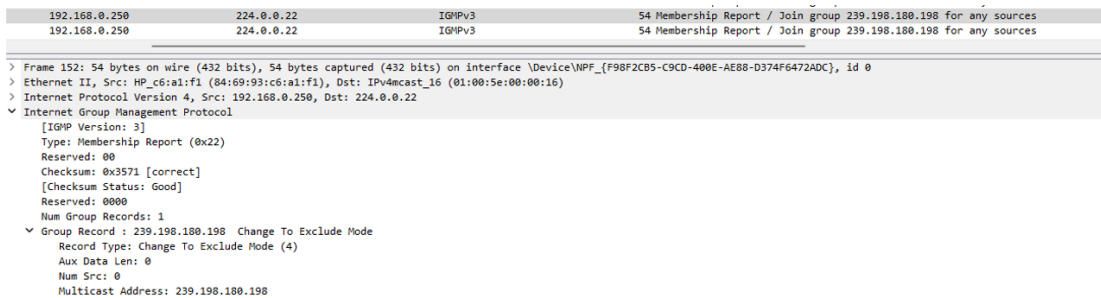

From the Wireshark trace, we can see the switch (the IGMP querier) sends out IGMP Membership query message to group 239.198.180.198.

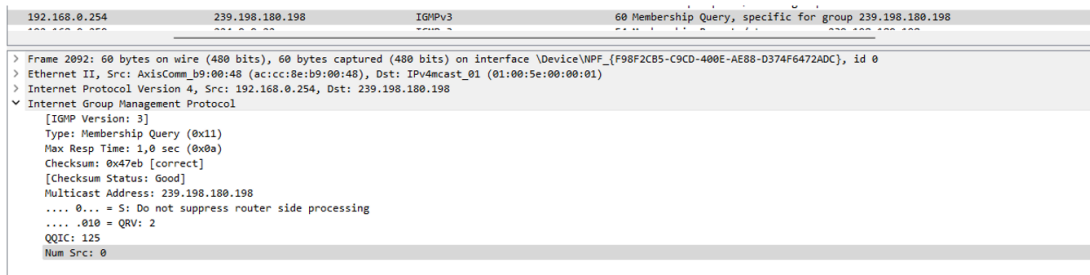

From the switch webpage, Choose Advanced > IPMC > Status > IGMP Snooping > Status. We can see the switch sends out queriers and receives reports.

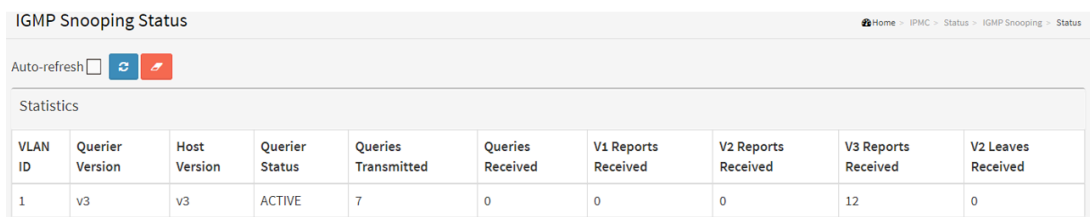

Checking the Wireshark trace, we can see the camera is sending multicast video stream to the group address 239.198.180.198.

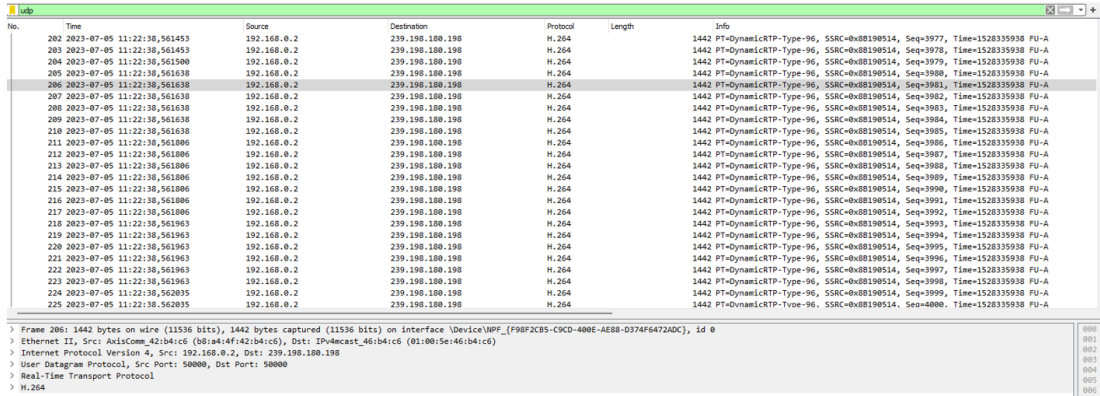

Check the IGMP Snooping group information on the switch. Choose Advanced > IPMC > Status > IGMP Snooping > Status > Groups Information. We can see port 1 and 2 belongs to multicast group 239.198.180.198.

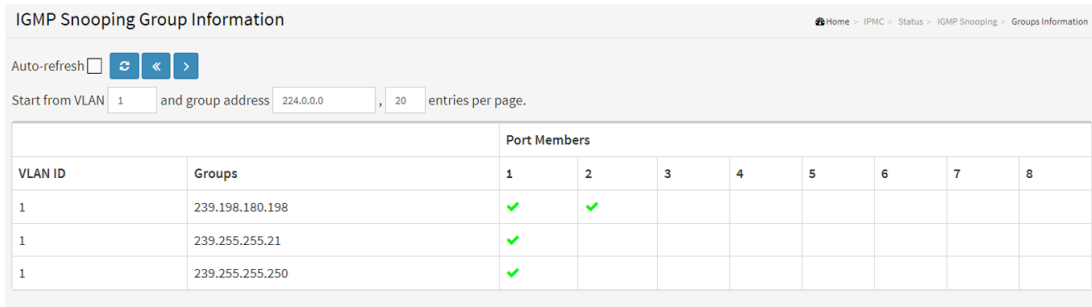

Syslog

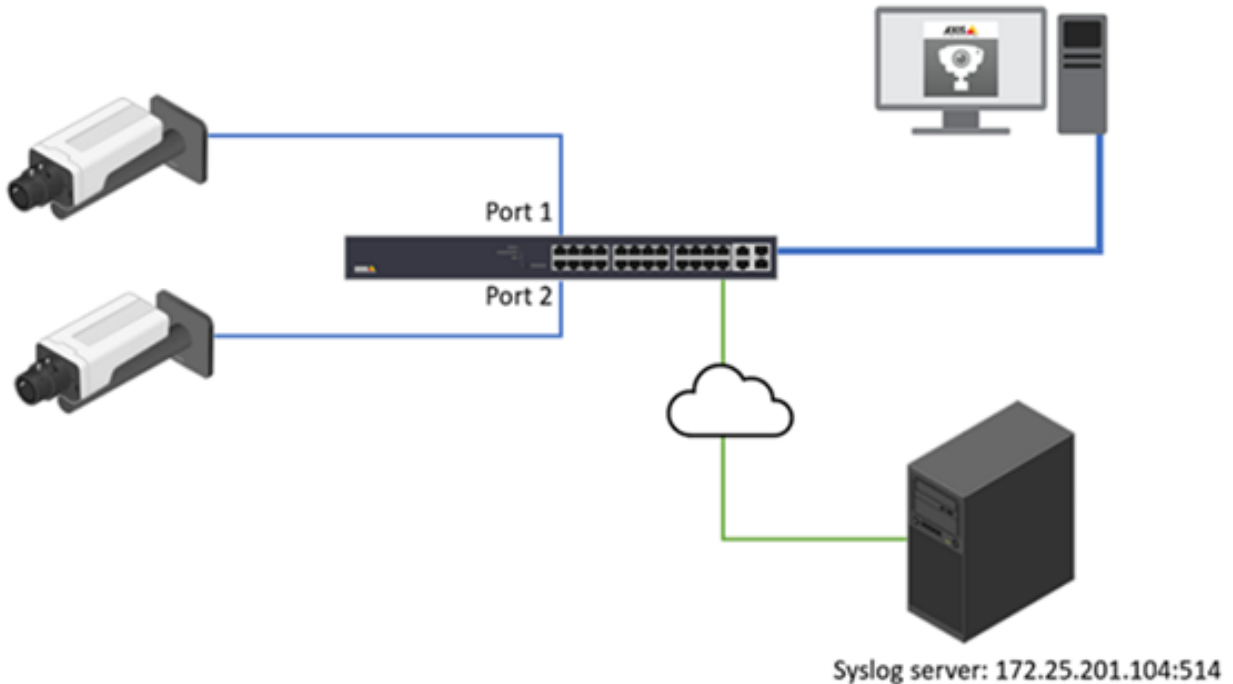

Syslog is a standard for message logging in IT devices. It is increasingly required in IT business applications and governance to facilitate, store, monitor and analyze audit logs from IT devices. The AXIS network switch can use the syslog protocol to send log messages to a server.

Choose Advanced > System > Configuration > Log.

System Log Configuration

Server Mode	Enabled ▾
Server Address	172.25.201.104
Server Port	514

SNMP

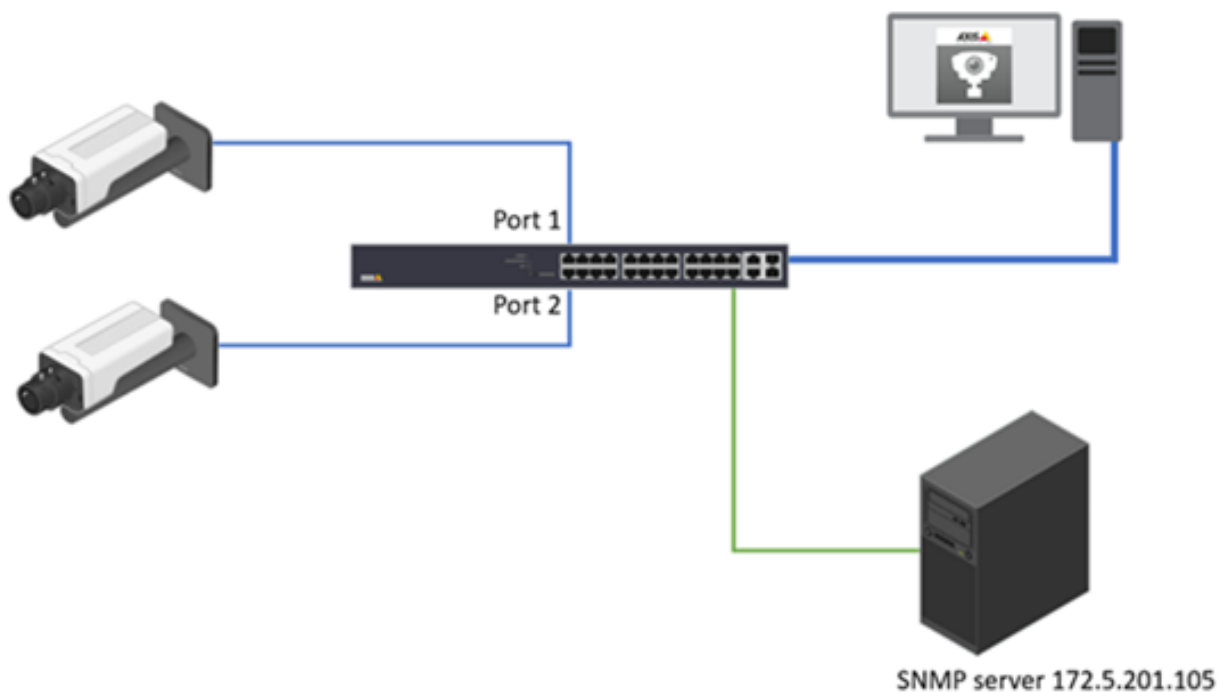

SNMP allows network management operators to use standard SNMP tools to monitor the status of Axis switches.

Basic Configuration:

Choose Advanced > Security > Switch > SNMP > System.

SNMP System Configuration

Mode	Enabled ▾
Version	SNMP v2c ▾
Read Community	public
Write Community	public
Engine ID	800007e5017f000001

Apply Reset

SNMP Trap

SNMP trap messages are used to inform the SNMP manager when an event occurs. In the below example, I will show you how to notify the SNMP manager when a user logs into the switch.

1. Choose Advanced > Security > Switch > SNMP > Trap and click Add new Entry. Enter the information needed and Click Apply.

SNMP Trap Configuration Home > Security > Configuration > Switch > SNMP > Trap

Trap Config Name	MySNMPTrap
Trap Mode	UDP ▾
Trap Version	SNMPv2c ▾
Trap Community	public
Trap Destination Address	172.25.201.105
Trap Destination Port	162
Trap Inform Mode	Disabled ▾
Trap Inform Timeout (seconds)	3
Trap Inform Retry Times	5
Trap Probe Security Engine ID	Enabled ▾
Trap Security Engine ID	
Trap Security Name	None ▾

Apply Reset

2. Enable the Trap operation. Select Enable and click Apply.

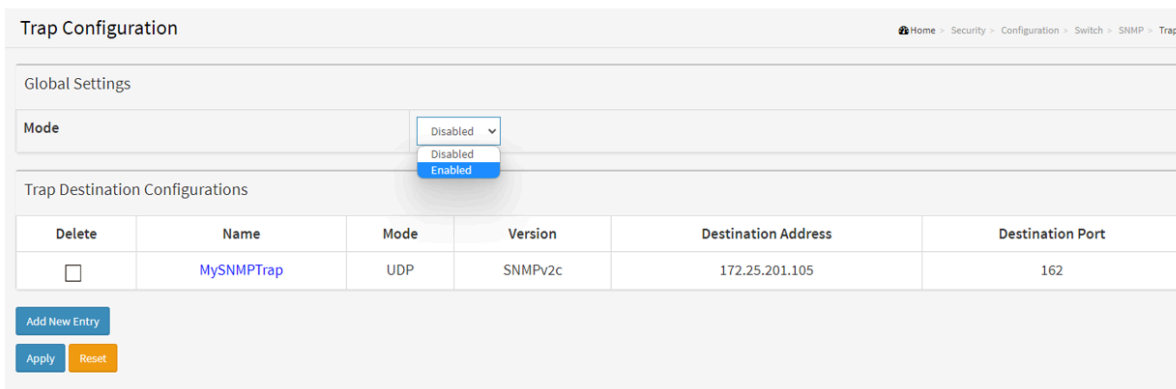

3. Choose Advanced > Security > Switch > SNMP > Trap Event Severity. Select Login and Logout. And click Apply.

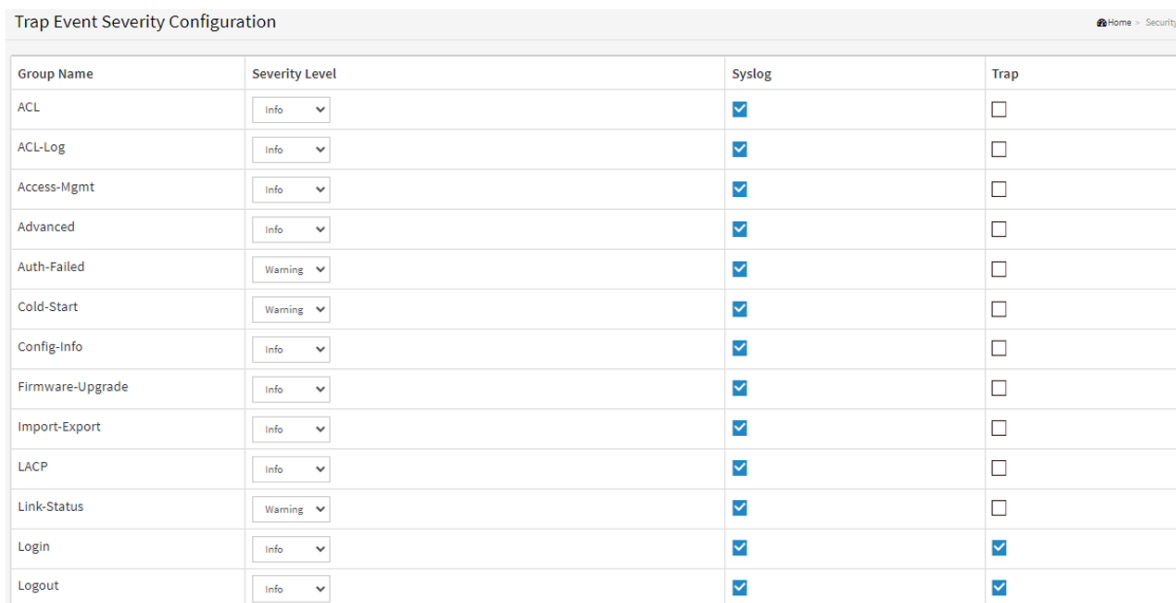

4. When a user logs into the switch, the SNMP manager receives a notification

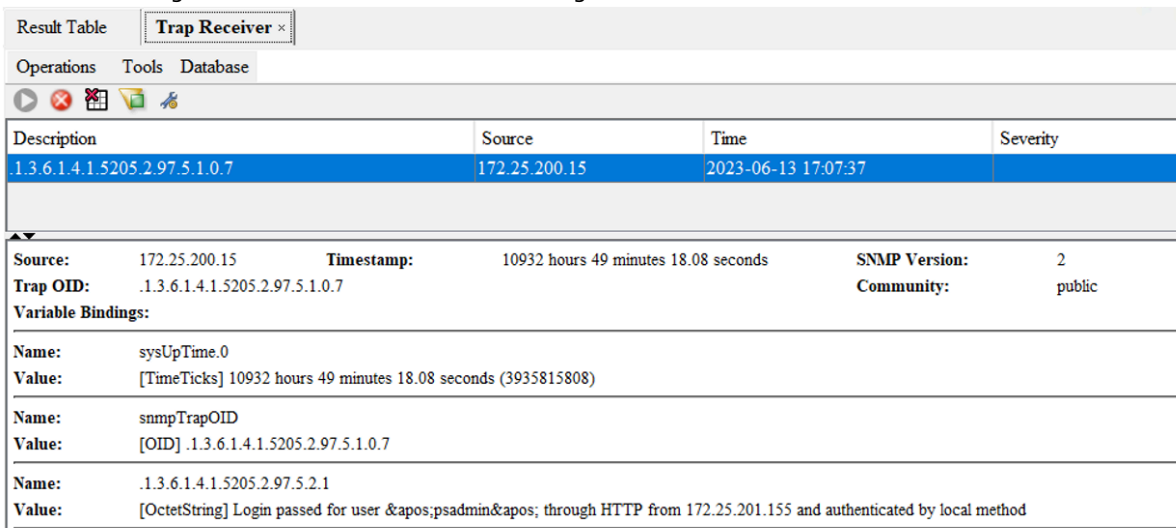

Port Mirroring

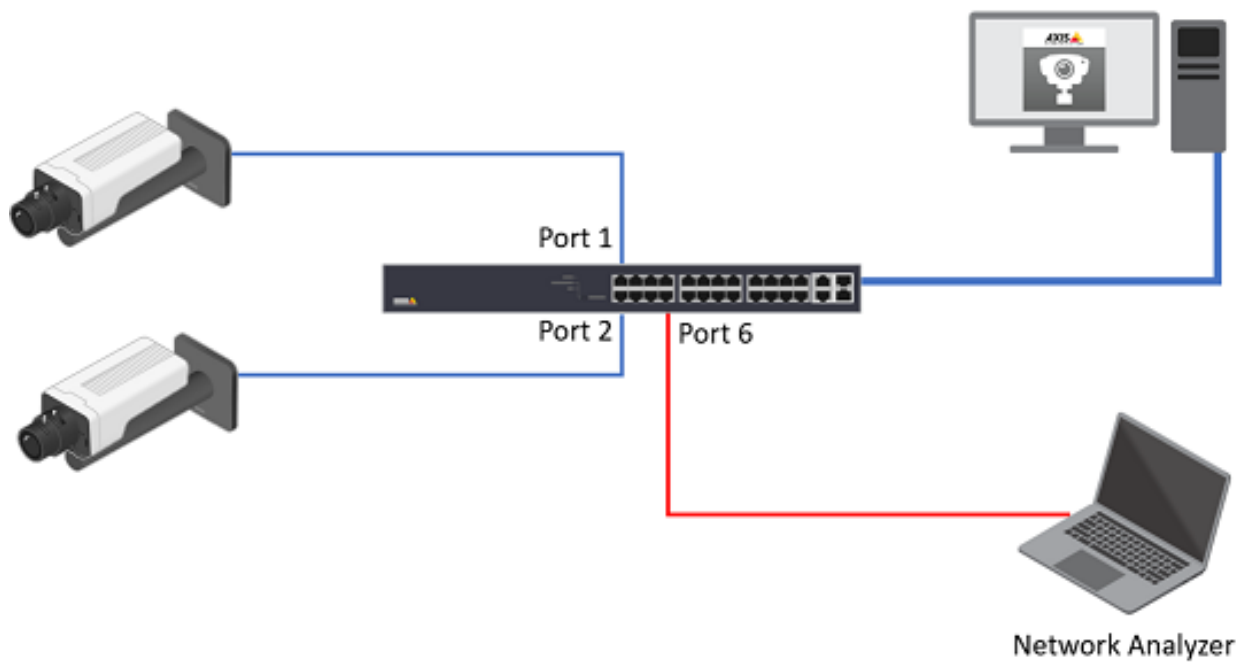

The network switch port mirroring allows the network administrator to monitor and analyze the network traffic. The switch copies the network traffic from one or more ports to a specific port for analysis.

The Network Analyzer is attached to Port 6. To monitor both ingress and egress traffic on port 1 and 2.

T8504-R, web interface.

1. Choose Advanced > Ports > Mirroring.

Mirror Configuration

Port to mirror to Disabled ▾

Mirror Port Configuration

Port	Mode
*	<> ▾
1	Disabled ▾
2	Disabled ▾
3	Disabled ▾
4	Disabled ▾
5	Disabled ▾
6	Disabled ▾
7	Disabled ▾
8	Disabled ▾
CPU	Disabled ▾

Apply Reset

2. Port to mirror to, select port 6. For ports 1 and 2, select "Enable" for the Mode.

Mirror Configuration

Port to mirror to 6 ▾

Mirror Port Configuration

Port	Mode
*	↔ ▾
1	Enabled ▾
2	Enabled ▾
3	Disabled ▾
4	Disabled ▾
5	Disabled ▾
6	Disabled ▾
7	Disabled ▾
8	Disabled ▾
CPU	Disabled ▾

Apply
Reset

3. Click Apply to save.

Optional. On T8504-R, this feature can be configured by CLI also.

```

AXIS T85 SW(config)# monitor session 1
AXIS T85 SW(config)# monitor session 1 source interface
GigabitEthernet 1/1-2 both
AXIS T85 SW(config)# monitor session 1 destination interface
GigabitEthernet 1/6
    
```

For T8508, T8516 and T8524, this feature can only be configured via CLI. Below are the example commands:

```

AXIS T85 SW(config)# monitor session 1
AXIS T85 SW(config)# monitor source interface
GigabitEthernet 1/1-2 both
AXIS T85 SW(config)# monitor destination interface GigabitEthernet
1/6
    
```

Switch Topology View

The topology view displays all the network devices connected to the switches. It is mainly designed for star, tree, and ring topology.

- It supports up to 256 devices within 4 subnets.
- Device list only supports displaying up to 256 devices including the offline devices in the list. To show the new devices connected to the network, users must manually remove offline devices.

- IP range on the config tab of the topology view only supports /24 as the subnet mask.
- All switches' gateway should be properly configured (Gateway and the switch's one of IP interface at the same network segment).
- When LACP is configured, the topology view may not work properly.

Enable or Disable the topology view

The topology view feature is enabled by default. It can only be disabled via the command line interface.

```
AXIS T85 SW(config) # conf tAXIS T85 SW(config) # dms service-mode disabled
```

To enable the topology view feature again:

```
AXIS T85 SW(config) # conf tAXIS T85 SW(config) # dms service-mode enabled
```

Configure the topology view when multiple VLANs exit

The topology view's controller will be elected when multiple switches are interconnected. The controller switch controls the topology view and is in charge of syncing all the necessary information. When multiple subnets or VLANs are involved, the controller must be configured with multiple IP interfaces for VLANs for polling end devices.

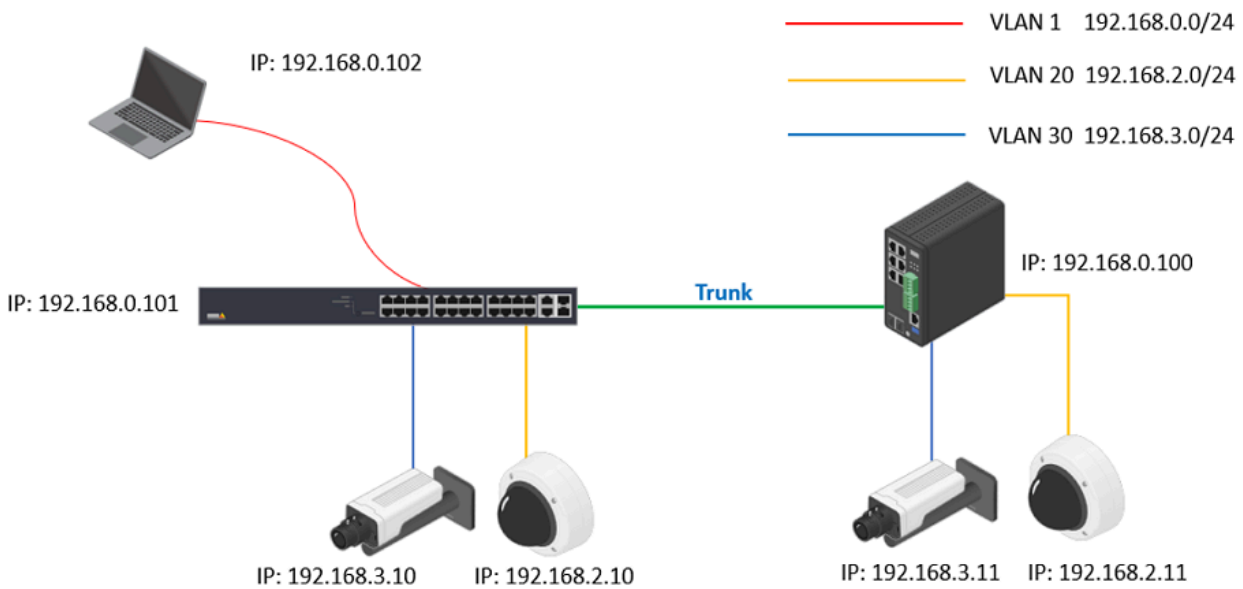

1. Log into the switches and create VLAN 1, VLAN 20 and VLAN 30 respectively. Assign the ports to the VLANS according to the network design.
2. Now all the cameras will not be displayed in Topology View.

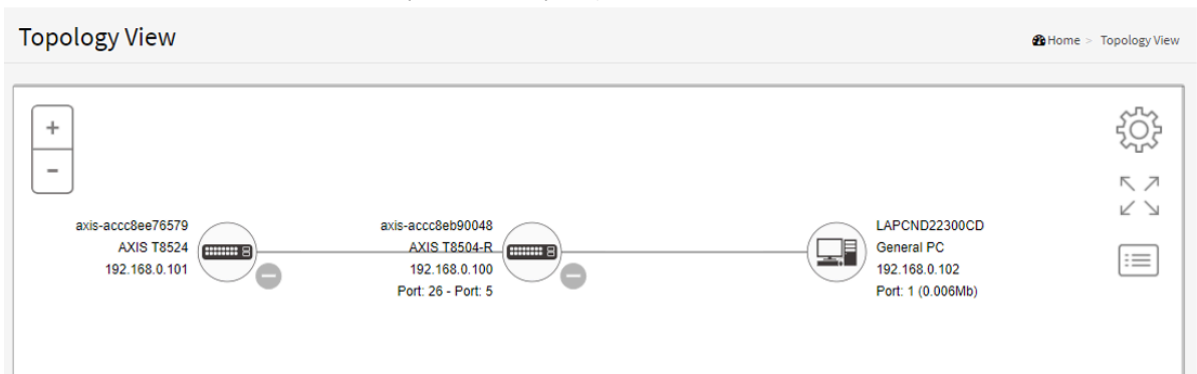

3. Figure out the Controller switch in the network. Click the Cogwheel in the Topology View > Config. The "Controller IP" is shown there. In our example, both 2 switches show "192.168.0.11".

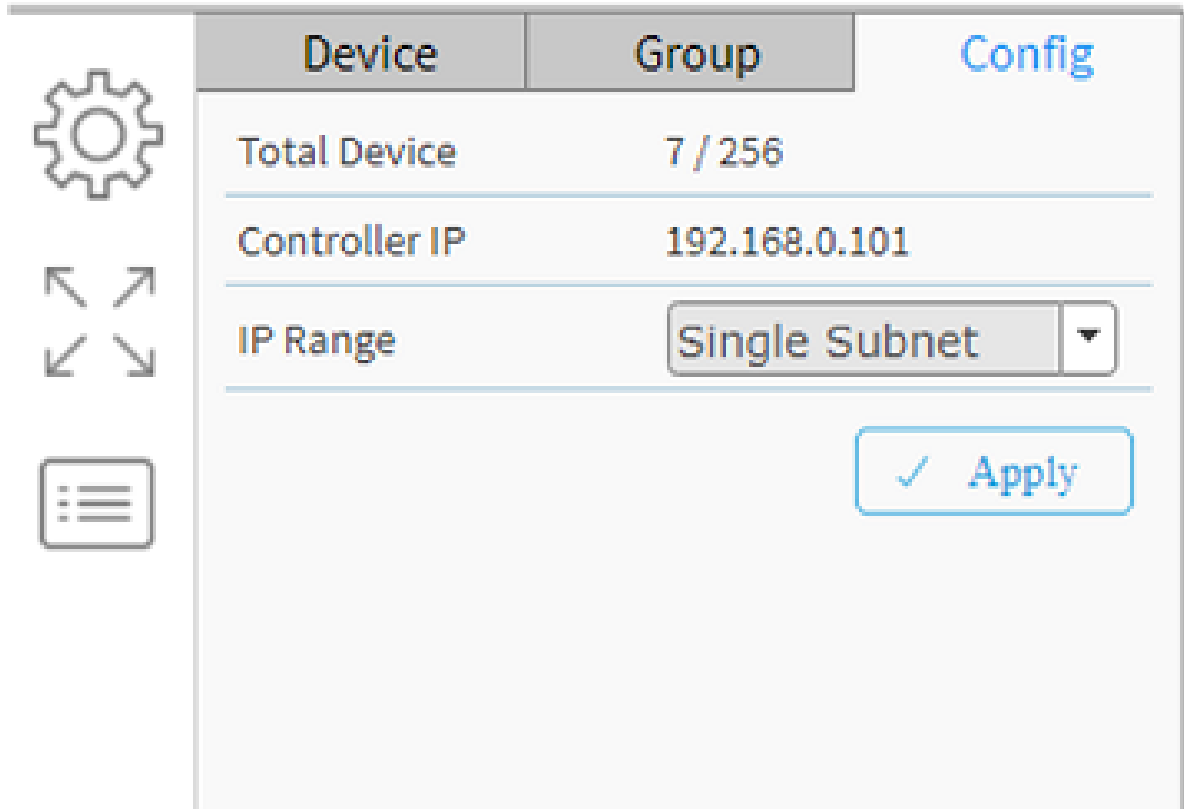

If you want to promote the other switch to the Controller, please log into that switch CLI interface via ssh or console cable and use below command.

```
AXIS T85 SW # configure terminal
AXIS T85 SW (config) # dms service-mode enabled priority high
```

4. Config the VLAN interfaces on the Controller switch. Choose Advanced > System > Configuration > IP. Under IP Interfaces, click "Add interface". In this example, we need to create VLAN interfaces 20 and 30.

IP Interfaces						
Delete	VLAN	IPv4 DHCP			IPv4	
		Enable	Fallback	Current Lease	Address	Mask Length
<input type="checkbox"/>	1	<input type="checkbox"/>	0		192.168.0.101	24
<input type="checkbox"/>	20	<input type="checkbox"/>	0		192.168.2.1	24
<input type="checkbox"/>	30	<input type="checkbox"/>	0		192.168.3.1	24

[Add Interface](#)

5. Click Apply to save settings.
6. After a while, all the cameras in different VLANs will be displayed in the Topology View.

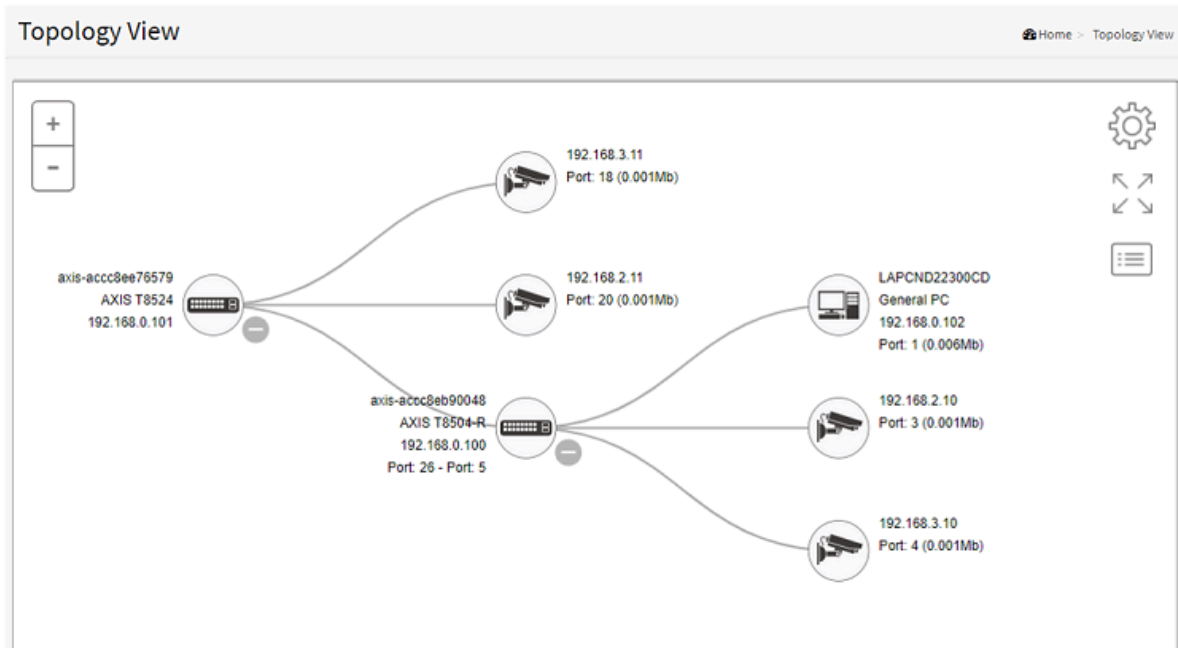

The command line interface

Basic commands

The CLI is divided into several modes. If a user has enough privilege to run a particular command, the user has to run the command in the correct mode. To see the commands of the mode, please input "?" after the system prompt, then all commands will be listed in the screen. The command modes are listed as below.

- To check the current running configuration:

```
AXIS T85 SW # show running-config
```

- To enter the configuration mode:

```
AXIS T85 SW # configure terminal
AXIS T85 SW (config) #
```

- Exit the configuration mode:

```
AXIS T85 SW (config) # exit
AXIS T85 SW #
```

- Logout:

```
AXIS T85 SW# exit
Please press enter after the "exit" command
AXIS T85 SW#exit
Connection to 172.25.200.24 closed by remote host.
Connection to 172.25.200.24 closed.
```

Banner

The banner message is commonly used to display warnings or informational messages. There are 3 different types of banner messages: message of the day(MOTD), Login Banner and exec banner.

- To configure the MOTD

```
AXIS T85 SW (config) # banner motd "-Welcome To the AXIS Switch Integration Guide-"
```

- The MOTD will be displayed next login.

```
C:\>ssh psadmin@192.168.0.20
psadmin@192.168.0.20's password:-Welcome To the AXIS Switch Integration Guide-
AXIS T85 SW#
```

- To configure the banner message when entering the EXEC mode.

```
AXIS T85 (config) # banner exec L
Enter TEXT message. End with the character 'L'.
#####The guide is intended for use by network administrators who are responsible for operating and maintaining network equipment; consequently, it assumes a basic working knowledge of general switch functions, the
```

Internet Protocol (IP), and Simple Network Management Protocol (SNMP).
L

- The next message will be displayed the next time entering the exec mode.

Press ENTER to get startedUsername: rootPassword:
#####The guide is intended for use by network administrators who are responsible for operating and maintaining network equipment; consequently, it assumes a basic working knowledge of general switch functions, the Internet Protocol (IP), and Simple Network Management Protocol (SNMP).
#####AXIS T85#

CLI documentation

You can find a complete list of CLI commands in the guides below.

Model	Guide
T8508	<i>Download</i>
T8516	
T8524	
T8504-R	<i>Download</i>
D8208-R	<i>Download</i>
D8248	<i>Download</i>
D8308	<i>Download</i>

Maintenance

Backup the current configurations

To backup the switch configurations, Choose Advanced > Maintenance > Configuration > Download. Select the files you want to download and click "Download Configuration". Download of running-config may take a little while to complete, as the file must be prepared for download.

Download Configuration Home > Maintenance > Configuration > Download

Select configuration file to save.

Please note: running-config may take a while to prepare for download.

File Name

running-config

default-config

startup-config

[Download Configuration](#)

Restore the configurations

To restore the configuration by uploading a configuration file that is saved locally, Choose Advanced > Maintenance > Configuration > Upload. If the destination is running-config, the file will be applied to the switch configuration.

This can be done in two ways:

- Replace mode: The current configuration is fully replaced with the configuration in the uploaded file.
- Merge mode: The uploaded file is merged into running-config.

Upload Configuration

Home > Maintenance > Configuration > Upload

File to Upload

No file chosen

Destination File

File Name

Parameters

running-config

Replace Merge

startup-config

Create new file

Troubleshooting

Basic troubleshooting steps for common issues

1. The switch has been installed properly according to the installation guide.
2. Check the LED lights status on the switches. For more information about the LED lights, please visit <https://help.axis.com> for the user manuals.
3. If the power is down, please check the power source and make sure the power cable is in good condition and properly connected.
4. If the link is down, check
 - If the network cable is properly connected or in good condition
 - Check the port configuration. For example the port has been administratively shutdown. Or check the speed and duplex settings.

Specific features not working as expected

1. Check the Network Topology design.
2. Follow the network design and make sure the configurations have been done correctly.
3. Verify the status of the feature.

Contact the Technical Support

When contacting the Technical Support, please make sure you have prepared:

1. Clear description of the issue you are experiencing.
2. The troubleshooting steps have been taken.
3. A network design topology
4. Server report from the switch. You can download the server reports from Basic > Maintenance > Server Reports.
5. Other information would be helpful to understand your issues. For example, a photo or a short video clip.

T10199017

2025-05 (M4.2)

© 2025 Axis Communications AB