

## **AXIS Camera Station S1148 Recorder**

**User manual**

# AXIS Camera Station S1148 Recorder

## Table of Contents

---

<b>About your device</b> .....	3
<b>Get started</b> .....	4
<b>Install your device</b> .....	5
<b>Configure your device</b> .....	13
First-time configuration .....	13
Configure AXIS Camera Station .....	13
License a system online .....	16
License a system offline .....	16
<b>Manage Windows® user accounts</b> .....	18
Create a user account .....	18
Create an administrator account .....	18
Create a local user group .....	18
Delete a user account .....	18
Change a user account's password .....	19
Create a password reset disk for a user account .....	19
<b>Manage AXIS Camera Station user accounts</b> .....	20
Configure user permissions .....	20
Add users or groups .....	20
User or group privileges .....	21
<b>Manage your device</b> .....	24
Update Windows® .....	24
Configure Windows update settings .....	24
Change the RAID .....	25
Add a hard drive .....	25
<b>Troubleshooting</b> .....	29
Check the current BIOS version .....	29
Upgrade BIOS .....	29
Run diagnostics .....	29
Perform a system recovery .....	29
Create a technical support report .....	30
Enable IDRAC .....	31
Troubleshoot the power supply unit .....	31
Troubleshoot memory errors .....	32
Troubleshoot AXIS Camera Station .....	32
<b>Product overview</b> .....	33
Front and rear sides .....	33
Specifications .....	34
<b>Need more help?</b> .....	38
Useful links .....	38
Contact support .....	38

# AXIS Camera Station S1148 Recorder

## About your device

---

### About your device

AXIS Camera Station S11 Recorder series consist of out-of-the-box ready rack servers and work stations validated for reliable high-definition surveillance up to 4K. For quick and easy installation, the recorder series is preconfigured and preloaded with AXIS Camera Station video management software including licenses plus all necessary system software. The system configuration can easily be imported from AXIS Site Designer, and AXIS Camera Station lets you take full advantage of Axis wide range of video surveillance devices. With redundant enterprise-grade hard disks, operating system stored on solid-state drive (SSD), the recorder series provides high-performance and reliability for your system.



To watch this video, go to the web version of this document.

*[help.axis.com/?&pid=46316&section=about-your-device](http://help.axis.com/?&pid=46316&section=about-your-device)*

# AXIS Camera Station S1148 Recorder

## Get started

---

### Get started

The standard workflow to configure an AXIS Camera Station recorder is:

- 1.
2. Configure Windows®. We recommend to:
  - Update Windows® to the latest version. See
  - Create a standard user account. See
- 3.
4. Update AXIS Camera Station to the latest version.
  - If your system is online: open the AXIS Recorder Toolbox app and click **Update AXIS Camera Station**.
  - If your system is offline: go to *axis.com* and download the latest version.
- 5.
6. Register you AXIS Camera Station licenses.
  - 
  -
7. Connect your system to the AXIS Camera Station mobile viewing app. See *Configure AXIS Secure Remote Access*



To watch this video, go to the web version of this document.

*[help.axis.com/?&tpald=46316&tsection=about-your-device](http://help.axis.com/?&tpald=46316&tsection=about-your-device)*

# AXIS Camera Station S1148 Recorder

## Install your device

---

### Install your device

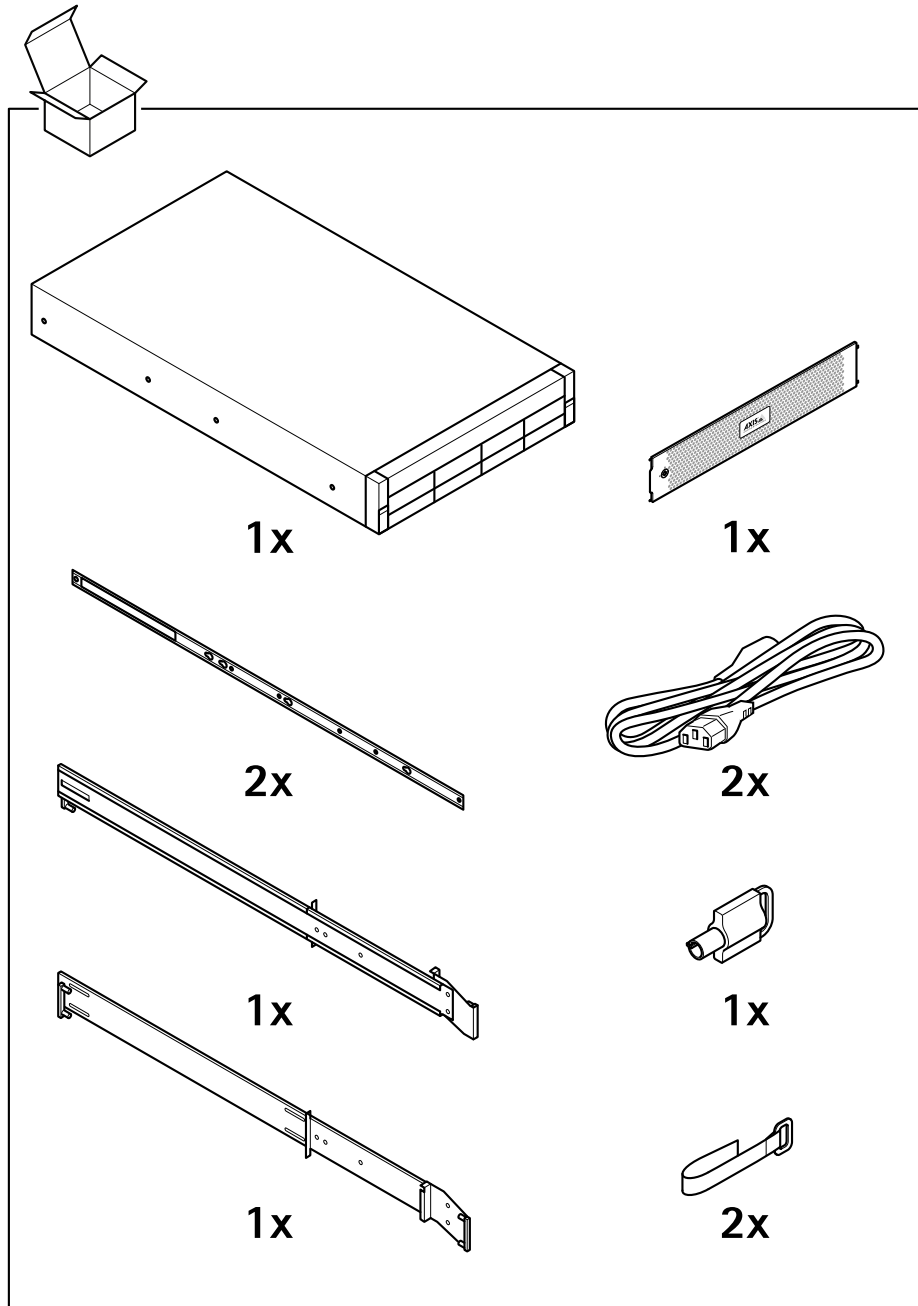

# AXIS Camera Station S1148 Recorder

## Install your device

---

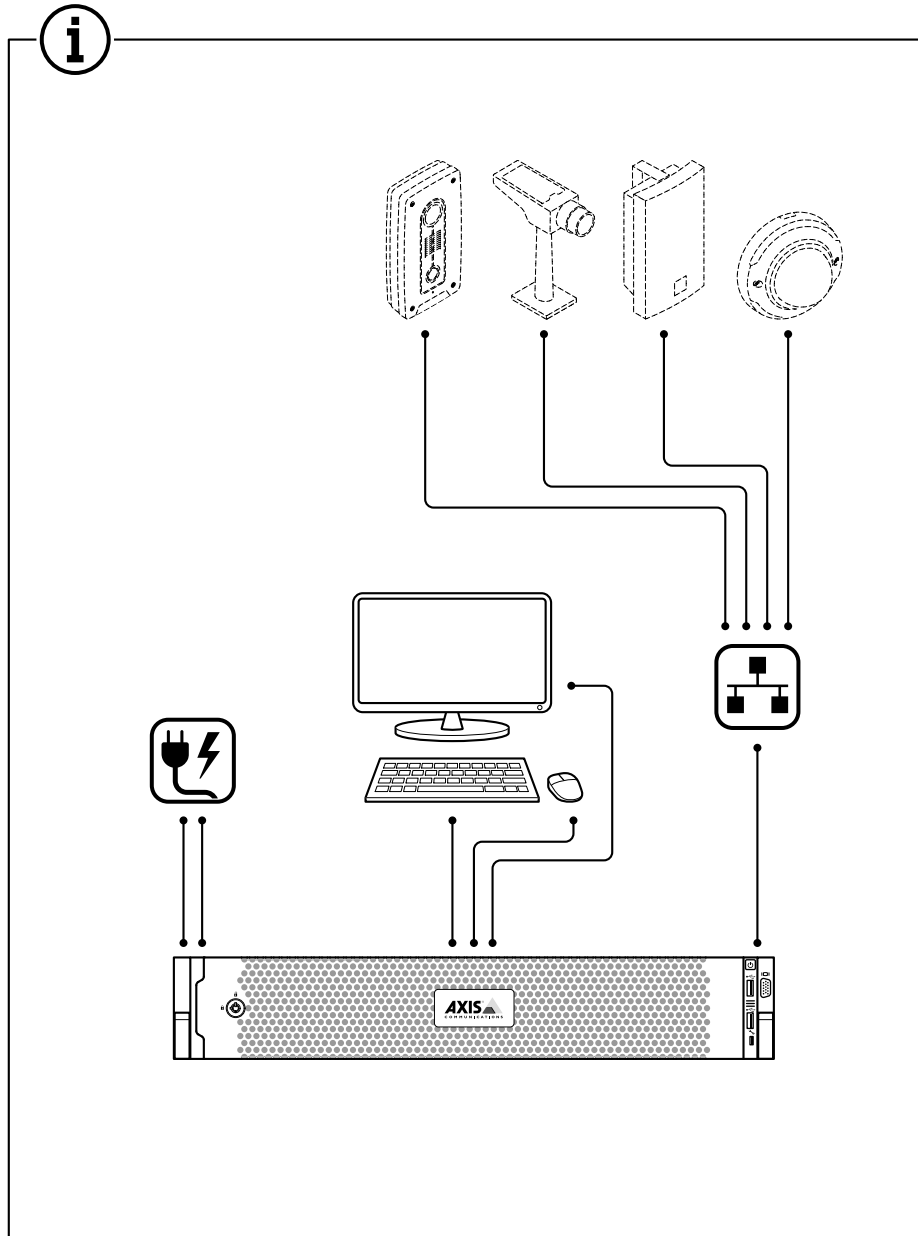

# AXIS Camera Station S1148 Recorder

## Install your device

---

### 1.1

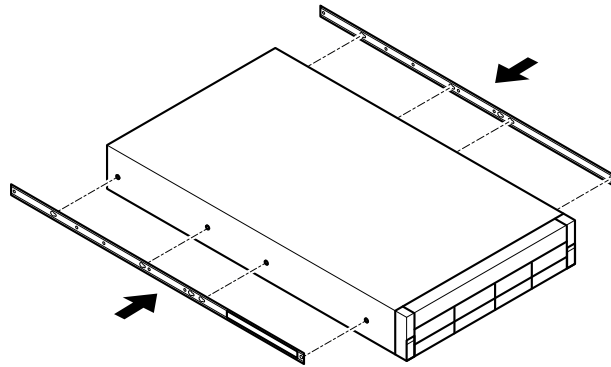

### 1.2

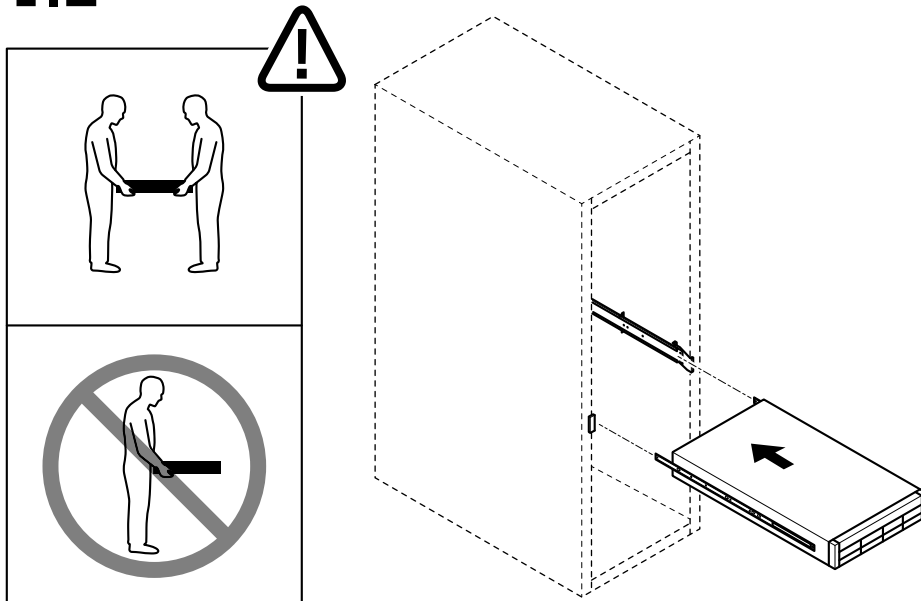

# AXIS Camera Station S1148 Recorder

## Install your device

---

### 1.3

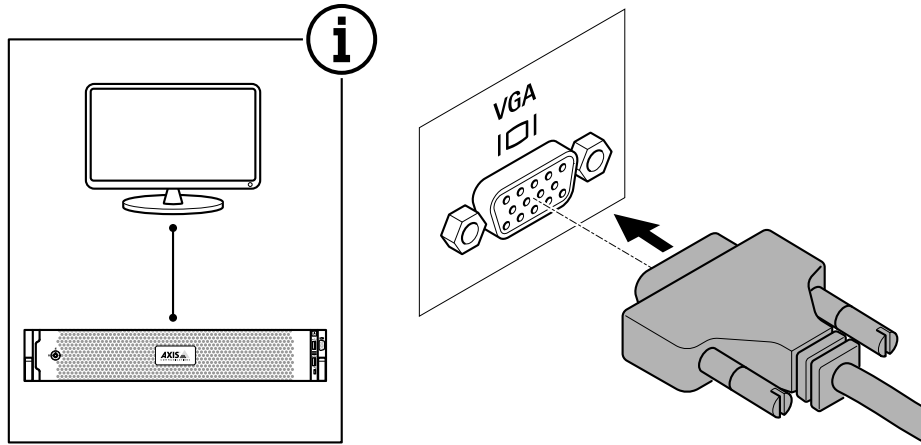

### 1.4

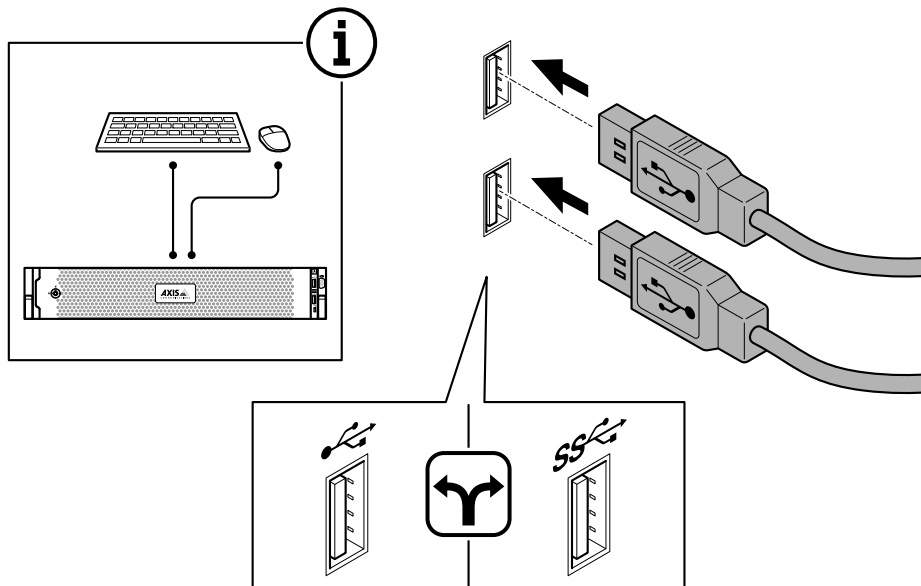



# AXIS Camera Station S1148 Recorder

## Install your device

### 1.5

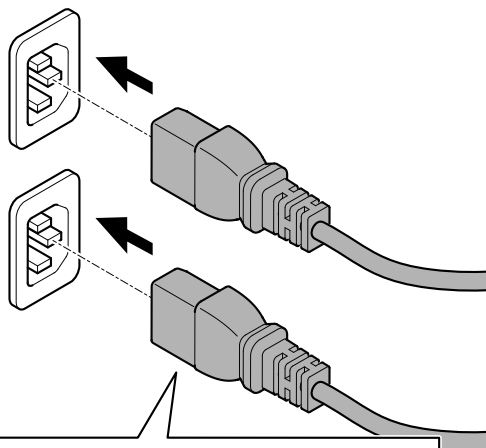
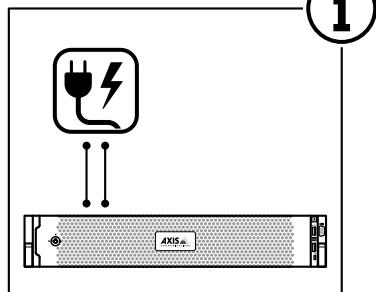

S1148 24 TB: 100-240 V AC 6.5-3 A (x2)  
S1148 64 TB: 100-240 V AC 10-5 A (x2)  
S1148 140 TB: 100-240 V AC 10-5 A (x2)

推奨電源ケーブル仕様(日本)

C13 - NEMA 5-15P, 2 m (6.5 ft), 120 V, 15 A (x2)

### 1.6

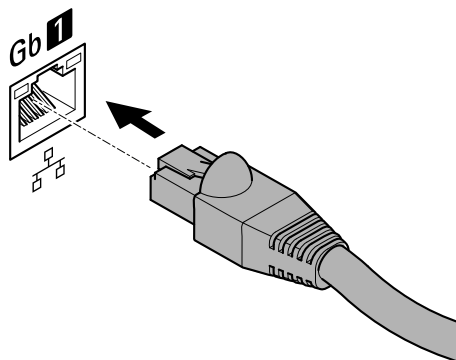
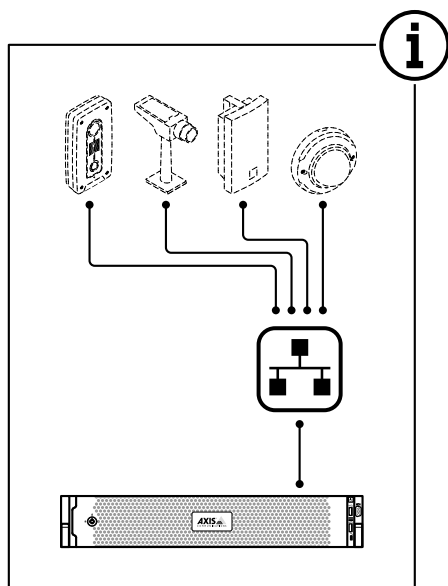

# AXIS Camera Station S1148 Recorder

## Install your device

---

**1.7**

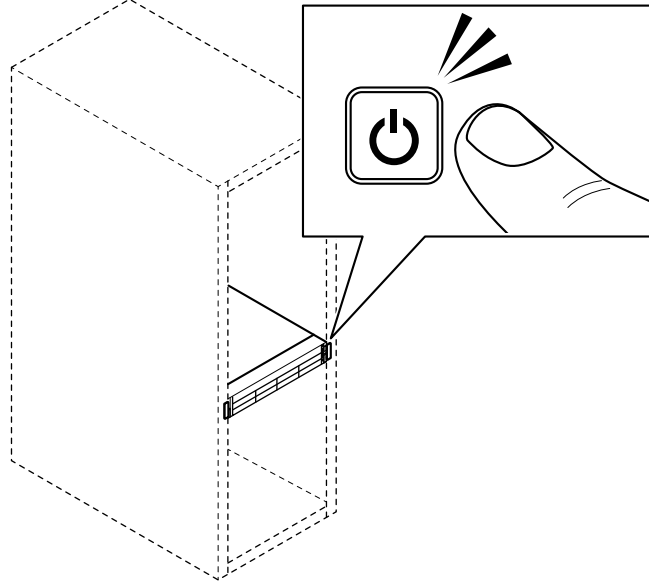

**1.8**

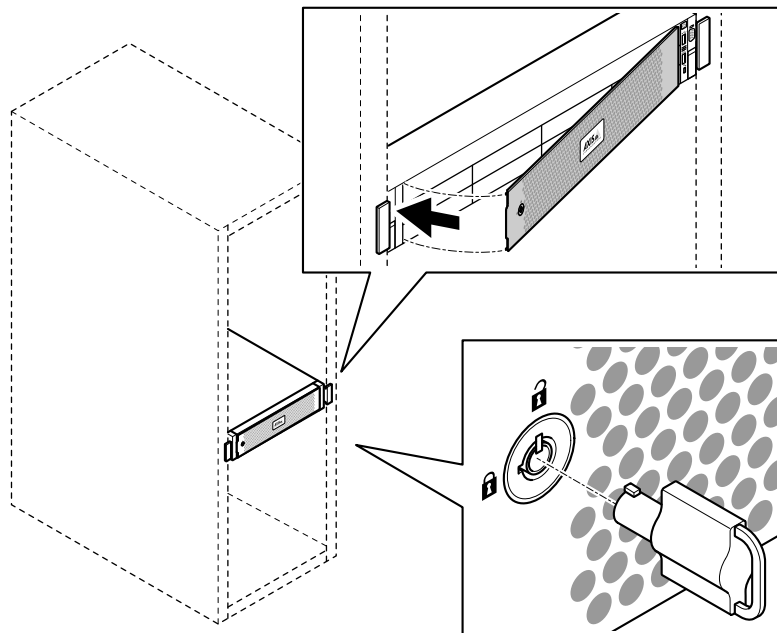

# AXIS Camera Station S1148 Recorder

## Install your device

---

### 1.9

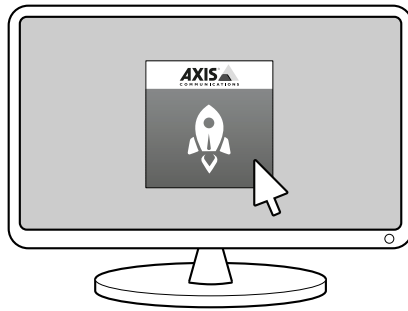

### 1.10

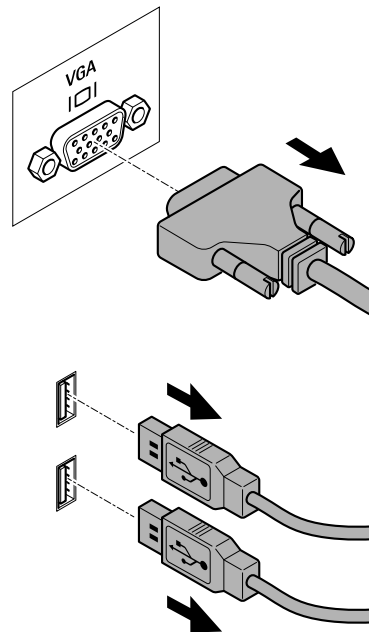
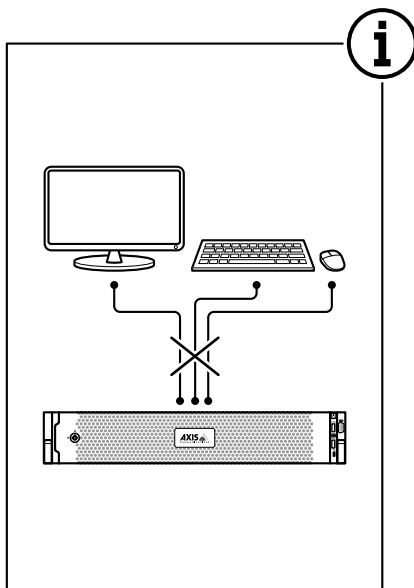

# AXIS Camera Station S1148 Recorder

## Install your device

---

### 1.11

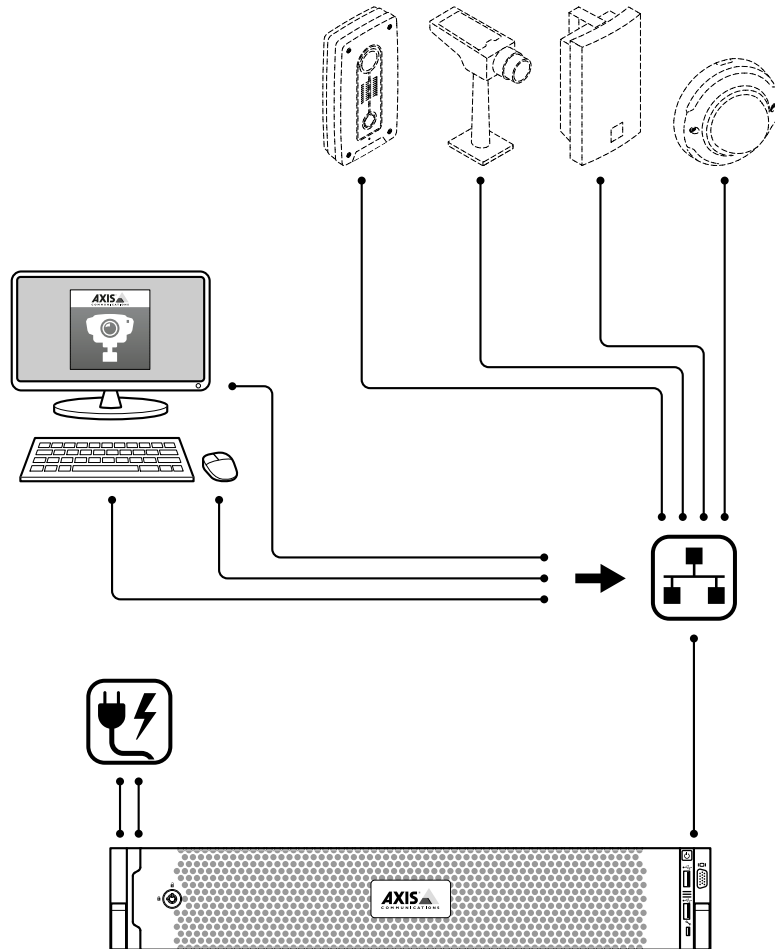

# AXIS Camera Station S1148 Recorder

## Configure your device

---

### Configure your device

#### First-time configuration



To watch this video, go to the web version of this document.  
[help.axis.com/?&pid=46316&section=first-time-configuration](http://help.axis.com/?&pid=46316&section=first-time-configuration)

After you have configured Windows®, AXIS Recorder Toolbox is opened automatically and you are guided through the first-time configuration wizard. In this wizard, you can configure several basic and necessary settings before you manage your device in AXIS Recorder Toolbox.

1. Change the computer name if you want and click **Next**.
2. Under **Date and time**, configure the following settings and click **Next**.
  - Select a time zone.
  - To set up an NTP server, select **NTP server** and enter the NTP server address.
  - To set manually, select **Manual** and select a date and time.
3. Under **Network settings**, configure the following settings and click **Next**.
  - **Use automatic IP settings (DHCP)** and **Use automatic DNS settings** are turned on by default.
  - If your device is connected to a network with a DHCP server, the assigned IP address, subnet mask, gateway, and preferred DNS are automatically displayed.
  - If your device is not connected to a network or there is no DHCP server available, enter the IP address, subnet mask, gateway, and preferred DNS manually depending on the network requirements.
4. Click **Finish**. If you have changed the computer name, AXIS Recorder Toolbox will prompt you to restart the device.

### Configure AXIS Camera Station

This Get started tutorial will walk you through the basic steps to make your system up and running.

Before you start, you may need to:

- Configure your network depending on your installation. See .
- Configure your server ports if needed. See .
- Consider security issues. See .

After necessary configurations, you can start to work with AXIS Camera Station:

- 1.

# AXIS Camera Station S1148 Recorder

## Configure your device

---

- 2.
- 3.
- 4.
- 5.
- 6.
- 7.
- 8.

### Start the video management system

Double-click the AXIS Camera Station client icon to start the client. When you start the client for the first time, it attempts to log in to the AXIS Camera Station server installed on the same computer as the client.

You can connect to multiple AXIS Camera Station servers in different ways.

### Add devices

The Add devices page opens the first time you start AXIS Camera Station. AXIS Camera Station searches the network for connected devices and shows a list of devices found.

1. Select the cameras you want to add from the list. If you can't find your camera, click **Manual search**.
2. Click **Add**.
3. Select **Quick configuration** or **Site Designer configuration**. Click **Next**.
4. Use the default settings and ensure the recording method is **None**. Click **Install**.

### Configure recording method

1. Go to **Configuration > Recording and events > Recording method**.
2. Select a camera.
3. Turn on **Motion detection**, or **Continuous**, or both.
4. Click **Apply**.

### View live video

1. Open a **Live view** tab.
2. Select a camera to view its live video.

### View recordings

1. Open a **Recordings** tab.
2. Select the camera you want to view recordings from.

### Add bookmarks

1. Go to the recording.
2. In the timeline of the camera, zoom in and out and move the timeline to put the marker at your desired position.

# AXIS Camera Station S1148 Recorder

## Configure your device

---



3. Click  .
4. Enter the bookmark name and description. Use keywords in the description to make the bookmark easy to find and recognize.
5. Select **Prevent recording deletion** to lock the recording.

### Note

It's not possible to delete a locked recording. To unlock the recording, clear the option or delete the bookmark.

6. Click **OK** to save the bookmark.

### Export recordings

1. Open a **Recordings** tab.
2. Select the camera you want to export recordings from.
3. Click  to display the selection markers.
4. Drag the markers to include the recordings that you want to export.
5. Click  to open the **Export** tab.
6. Click **Export....**

### Play and verify recordings in AXIS File Player

1. Go to the folder with the exported recordings.
2. Double-click **AXIS File Player**.
3. Click  to show the recording's notes.
4. To verify the digital signature:
  - 4.1 Go to **Tools > Verify digital signature**.
  - 4.2 Select **Validate with password** and enter your password.
  - 4.3 Click **Verify**. The verification result page appears.

### Note

Digital signature is different from Signed video. Signed video allows you to trace video back to the camera it came from, making it possible to verify that the recording wasn't tampered with. See *Signed video* and the camera's user manual for more information.

### Network configuration

Configure proxy or firewall settings before using AXIS Camera Station if the AXIS Camera Station client, AXIS Camera Station server, and the connected network devices are on different networks.

#### Client proxy settings

When a proxy server separates the client and the server, configure the client proxy settings.

1. Open the **AXIS Camera Station client**.
2. Click **Change client proxy settings**.

# AXIS Camera Station S1148 Recorder

## Configure your device

---

3. Change the client proxy settings.
4. Click OK.

### Server proxy settings

When a proxy server separates the network devices and the server, configure the server proxy settings.

1. Open AXIS Camera Station Service Control.
2. Select **Modify settings**.
3. In the Proxy settings section, use the default **System account internet option** or select **Use manual proxy settings**.
4. Click **Save**.

### NAT and Firewall

When a NAT, firewall, or similar separates the client and the server, configure the NAT or firewall to ensure that the HTTP port, TCP port, and streaming port specified in AXIS Camera Station Service Control can pass through the firewall or NAT. Contact the network administrator for instructions on configuring the NAT or firewall.

### Server port configuration

AXIS Camera Station server uses ports 55752 (HTTP), 55754 (TCP), 55756 (mobile communication), and 55757 (mobile streaming) for communication between the server and the client. You can change the ports in AXIS Camera Station Service Control if required.

### Security considerations

To prevent unauthorized access to cameras and recordings, keep the following in mind:

- Use strong passwords for all network devices (cameras, video encoders, and auxiliary devices).
- Install AXIS Camera Station S1148 Recorder server, cameras, video encoders, and auxiliary devices on a secure network separate from the office network. You can install the AXIS Camera Station S1148 Recorder client on a computer on another network, for example, a network with internet access.
- Make sure all users have strong passwords. Windows Active Directory provides a high level of security.

### License a system online

Both the AXIS Camera Station client and the server must have internet connection.

1. Go to **Configuration > Licenses > Management**.
2. Make sure **Manage licenses online** turns on.
3. Sign in with your My Axis account.
4. The license key automatically generates and appears under **License keys**.
5. If you purchased license keys separately, enter your license key under **Add license key**.
6. Click **Add**.
7. In AXIS Camera Station client, make sure your license keys appear under **Configuration > Licenses > Keys**.

### License a system offline

1. Go to **Configuration > Licenses > Management**.
2. Turn off **Manage licenses online**.



# AXIS Camera Station S1148 Recorder

## Configure your device

---

3. Click **Export system file**.
4. Save your system file to a USB flash drive.
5. Go to AXIS License Portal, [axis.com/licenses](https://axis.com/licenses),
6. Sign in with your My Axis account.
7. Click **Upload system file** to upload the system file from your USB flash drive.
8. The license key automatically generates and shows under **License keys**.
9. If you purchased license keys separately, enter your license key under **Add license key**.
10. Click **Add**.
11. Under **License keys**, click **Download license file** and save the file to a USB flash drive.
12. In AXIS Camera Station client, go to **Configuration > Licenses > Management**.
13. Click **Import license file** and select the license file on your USB flash drive.
14. Make sure your license keys appear under **Configuration > Licenses > Keys**.

# AXIS Camera Station S1148 Recorder

## Manage Windows® user accounts

---

### Manage Windows® user accounts

#### Create a user account

To help keep your personal data and information more secure, we recommend that you add a password for each local account.

##### Important

Once you create a password for a local account, don't forget it. There's no way to recover a lost password for local accounts.

1. Go to **Settings > Accounts > Other people > Add someone else to this PC**.
2. Click **I don't have this person's sign-in information**.
3. Click **Add a user without a Microsoft account**.
4. Enter a user name, password and password hint.
5. Click **Next** and follow the instructions.

#### Create an administrator account

1. Go to **Settings > Accounts > Other people**.
2. Go to the account you want to change and click **Change account type**.
3. Go to **Account type** and select **Administrator**.
4. Click **OK**.
5. Restart your device and sign in with the new administrator account.

#### Create a local user group

1. Go to **Computer Management**.
2. Go to **Local Users and Groups > Group**.
3. Right-click **Group** and select **New Group**.
4. Enter a group name and a description.
5. Add group members:
  - 5.1 Click **Add**.
  - 5.2 Click **Advanced**.
  - 5.3 Find the user account(s) you want to add to the group and click **OK**.
  - 5.4 Click **OK** again.
6. Click **Create**.

#### Delete a user account

##### Important

When you delete an account you remove the user account from the login screen. You also remove all files, settings and program data stored on the user account.

# AXIS Camera Station S1148 Recorder

## Manage Windows® user accounts

---

1. Go to **Settings > Accounts > Other people**.
2. Go to the account you want to remove and click **Remove**.

### Change a user account's password

1. Log in with an administrator account.
2. Go to **User Accounts > User Accounts > Manage another account in sequence**.  
You'll see a list with all user accounts on the device.
3. Select the user account whose password you would like to change.
4. Click **Change the password**.
5. Enter the new password and click **Change password**.

### Create a password reset disk for a user account

We recommend to create a password reset disk on a USB flash drive. With this, you can reset the password. Without a password reset disk, you can't reset the password.

#### Note

If you're using Windows 10, or later, you can add security questions to your local account in case you forget your password, so you don't need to create a password reset disk. To do this, go to **Start** and click **Settings > Sign-in options > Update your security questions**.

1. Sign in to your device with a local user account. You can't create a password reset disk for a connected account.
2. Plug an empty USB flash drive into your device.
3. From the Windows search field, go to **Create a password reset disk**.
4. In the **Forgotten Password** setup assistant, click **Next**.
5. Select your USB flash drive and click **Next**.
6. Type your current password and click **Next**.
7. Follow the onscreen instructions.
8. Remove the USB flash drive and keep it in a safe place. You don't have to create a new disk when you change your password even if you change it several times.

# AXIS Camera Station S1148 Recorder

## Manage AXIS Camera Station user accounts

---

### Manage AXIS Camera Station user accounts

#### Configure user permissions



Go to **Configuration > Security > User permissions** to view the users and groups that exists in AXIS Camera Station S1148 Recorder.

##### Note

Administrators of the computer that runs AXIS Camera Station S1148 Recorder server are automatically given administrator privileges to AXIS Camera Station S1148 Recorder. You can't change or remove the Administrators group's privileges.

Before you can add a user or group, register the user or group on the local computer or make sure they have an Windows Active Directory user account. To add users or groups, see .

When a user is part of a group, the user gets the highest role permission assigned to the individual or the group. The user also gets the access granted as an individual and receives the rights as part of a group. For example, a user has access to camera X as an individual. The user is also a member of a group that has access to cameras Y and Z. The user therefore has access to cameras X, Y, and Z.

	Indicates the entry is a single user.
	Indicates the entry is a group.
<b>Name</b>	Username as it appears in the local computer or Active Directory.
<b>Domain</b>	The domain that the user or group belongs to.
<b>Role</b>	The access role given to the user or group. Possible values: Administrator, Operator, and Viewer.
<b>Details</b>	Detailed user information as it appears in the local computer or Active Directory.
<b>Server</b>	The server that the user or group belongs to.

#### Add users or groups

Microsoft Windows and Active Directory users and groups can access AXIS Camera Station S1148 Recorder. To add a user to AXIS Camera Station S1148 Recorder, you must add users or a group to Windows.

To add a user in Windows vary depending on which version of Windows you use. Follow the instructions on *Microsoft's site*. If you use an Active Directory domain network, consult your network administrator

##### Add users or groups

1. Go to **Configuration > Security > User permissions**.
2. Click **Add**.  
You can see the available users and groups in the list.
3. Under **Scope**, select where to search for users and groups.
4. Under **Show**, select to show users or groups.  
The search result doesn't display if there are too many users or groups. Use the filter function.
5. Select the users or groups and click **Add**.

# AXIS Camera Station S1148 Recorder

## Manage AXIS Camera Station user accounts

---

Scope	
Server	Select to search for users or groups on the local computer.
Domain	Select to search for Active Directory users or groups.
Selected server	When connected to multiple AXIS Camera Station S1148 Recorder servers, select a server from the Selected server drop-down menu.

### Configure a user or group

1. Select a user or group in the list.
2. Under **Role**, select **Administrator**, **Operator**, or **Viewer**.
3. If you selected **Operator** or **Viewer**, you can configure the user or group privileges. See .
4. Click **Save**.

### Remove a user or group

1. Select the user or group.
2. Click **Remove**.
3. In the pop-up dialog, click **OK** to remove the user or group.

## User or group privileges

There are three roles you can give to a user or group. For how to define the role for a user or group, see .

**Administrator** - Full access to the entire system, including access to live and recorded video of all cameras, all I/O ports, and views. This role is required to configure anything in the system.

**Operator** - Select cameras, views, and I/O ports to get access to live and recorded. An operator has full access to all functionality of AXIS Camera Station S1148 Recorder except system configuration.

**Viewer** - Access to live video of selected cameras, I/O ports, and views. A viewer doesn't have access to recorded video or system configuration.

### Cameras

The following access privileges are available for users or groups with the **Operator** or **Viewer** role.

Access	Allow access to the camera and all camera features.
Video	Allow access to live video from the camera.
Audio listen	Allow access to listen from the camera.
Audio speak	Allow access to speak to the camera.
Manual Recording	Allow to start and stop recordings manually.
Mechanical PTZ	Allow access to mechanical PTZ controls. Only available for cameras with mechanical PTZ.
PTZ priority	Set the PTZ priority. A lower number means a higher priority. No assigned priority is set to 0. An administrator has the highest priority. When a role with higher priority operates a PTZ camera, others can't operate the same camera for 10 seconds by default. Only available for cameras with mechanical PTZ and have <b>Mechanical PTZ</b> selected.

# AXIS Camera Station S1148 Recorder

## Manage AXIS Camera Station user accounts

---

### Views

The following access privileges are available for users or groups with the **Operator** or **Viewer** role. You can select multiple views and set the access privileges.

Access	Allow access to the views in AXIS Camera Station S1148 Recorder.
Edit	Allow to edit the views in AXIS Camera Station S1148 Recorder.

### I/O

The following access privileges are available for users or groups with the **Operator** or **Viewer** role.

Access	Allow full access to the I/O port.
Read	Allow to view the state of the I/O port. The user can't change the port state.
Write	Allow to change the state of the I/O port.

### System

You can't configure greyed out access privileges in the list. Privileges with check mark means the user or group have this privilege by default.

The following access privileges are available for users or groups with the **Operator** role. **Take snapshots** is also available for the **Viewer** role.

Take snapshots	Allow to take snapshots in the live view and recordings modes.
Export recordings	Allow to export recordings.
Generate incident report	Allow to generate incident reports.
Prevent access to recordings older than	Prevent access to recordings older than the specified number of minutes. When using search, the user doesn't find recordings older than the specified time.
Access alarms, tasks, and logs	Get alarm notifications and allow access to the <b>Alarms and tasks</b> bar and <b>Logs</b> tab.
Access data search	Allow searching for data to track what happened at the time of an event.

### Access control

The following access privileges are available for users or groups with the **Operator** role. **Access Management** is also available for the **Viewer** role.

Access control configuration	Allow configuration of doors and zones, identification profiles, card formats and PIN, encrypted communication, and multi-server.
Access management	Allow access management and access to the active directory settings.

### System health monitoring

The following access privileges are available for users or groups with the **Operator** role. **Access to system health monitoring** is also available for the **Viewer** role.

# AXIS Camera Station S1148 Recorder

## Manage AXIS Camera Station user accounts

---

Configuration of system health monitoring	Allow configuration of the system health monitoring system.
Access to system health monitoring	Allow access to the system health monitoring system.

# AXIS Camera Station S1148 Recorder

## Manage your device

---

### Manage your device

#### Update Windows®

Windows® periodically checks for updates. When an update is available, your device automatically downloads the update but you've to install it manually.

##### Note

Recording will be interrupted during a scheduled system restart.

To manually check for updates:

1. Go to **Settings > Update & Security > Windows Update**.
2. Click **Check for updates**.

#### Configure Windows update settings

It is possible to change how and when Windows® do its updates to suit your needs.

##### Note

All ongoing recordings stop during a scheduled system restart.

1. Open the Run app.
  - Go to **Windows System > Run**, or
2. Type `gpedit.msc` and click **OK**. The Local Group Policy Editor opens.
3. Go to **Computer Configuration > Administrative Templates > Windows Components > Windows Update**.
4. Configure the settings as required, see example.

##### Example:

To automatically download and install updates without any user interaction and have the device restart, if necessary, at out of office hours, use the following configuration:

5. Open **Always automatically restart at the scheduled time** and select:
  - 5.1 **Enabled**
  - 5.2 **The restart timer will give users this much time to save their work (minutes): 15.**
  - 5.3 **Click OK.**
6. Open **Configure Automatic Updates** and select:
  - 6.1 **Enabled**
  - 6.2 **Configure Automatic updates: Auto download and schedule the install**
  - 6.3 **Schedule Install day: Every Sunday**
  - 6.4 **Schedule Install time: 00:00**
  - 6.5 **Click OK.**
7. Open **Allow Automatic Updates immediate installation** and select:
  - 7.1 **Enabled**



# AXIS Camera Station S1148 Recorder

## Manage your device

---

7.2 Click OK.

### Change the RAID

#### ⚠CAUTION

Changing the RAID deletes all data from your disks.

1. Boot Lifecycle Controller:
  - 1.1 Power on your device.
  - 1.2 When you see the AXIS splash screen, press F10.
2. In the Lifecycle Controller, go to **Hardware Configuration > Configuration Wizards** and select **RAID Configuration**.
3. Select the **RAID Controller** on which you want to have the RAID created. Details of any virtual disk(s) available on the selected controller will be shown in the table displayed on the page below the controller list. *Foreign Configuration* will be displayed if there are any foreign or uninitialized HDD(s) available on the server.

#### Note

- Clear foreign configuration clears all the foreign HDDs available on the RAID controller selected.
  - Ignore foreign Configuration ignores the foreign HDDs available on the RAID controller while creating the RAID.
4. Clear or ignore foreign HDDs and uninitialized HDDs.

If you want, you can initialize the uninitialized disks:

    - 4.1 In the list of all non-RAID (uninitialized) HDDs, select the HDDs you want to convert to RAID capable (initialize) and click **Next** to initialize them.
    - 4.2 Select the corresponding option on the Configuration Wizards: RAID Configuration page.
  5. Select a RAID level. The default settings are:
    - S1148 24 TB: RAID 5
    - S1148 64 TB: RAID 5
    - S1148 140 TB: RAID 6
    - S1132: RAID 5
  6. Select the physical disks from the table and click **Next**.

If the you've selected **Ignore foreign configuration**, the foreign HDDs are not displayed in the table.
  7. Enter the virtual disk attributes.
  8. Click **Next**.
  9. Review the settings and click **Finish**.
  10. Lifecycle Controller displays a message to indicate that all the current data about the virtual disks available on the controller will be lost. Click **OK** to continue.
  11. Click **OK** and **Finish**.
  12. Exit the wizard and reboot the system.

# AXIS Camera Station S1148 Recorder

## Manage your device

---

### Add a hard drive

This section explains how to install a hard drive, how you add it to the existing RAID array, and what you must configure in Windows®.

#### Note

You can only add a hard drive to S1148 24 TB and S1148 64 TB.

#### Note

The following instructions are to be used when adding additional storage in to the AXIS S11-series. These instructions are as is, and Axis Communications AB takes no responsibility for loss of data and/or configuration during these steps. The standard precautions should be taken to backup data that is business critical. The following procedure of expanding storage will not be supported by Axis Technical Support.

#### Note

To avoid electrostatic discharge, it is recommended that you always use a static mat and static strap while working on components in the interior of the system.

### Warranty

Axis Communications AB grants to the original purchaser (the distributor) a hardware warranty for the network video recorders mentioned above. Detailed information about warranty is available at: [axis.com/support/warranty-and-rma/warranty](http://axis.com/support/warranty-and-rma/warranty).

### Workflow

- 1.
- 2.
- 3.
- 4.

### Remove the bezel

1. Locate the bezel key.
2. Unlock the bezel by using the key.
3. Slide the release latch up and pull the left end of the bezel.
4. Unhook the right end and remove the bezel.

### Install the hard drive

#### ▲CAUTION

- Use only hard drives that have been tested and approved for use with AXIS S1148.
  - When installing a hard drive, ensure that the adjacent drives are fully installed. Inserting a hard drive carrier and attempting to lock its handle next to a partially installed carrier can damage the partially installed carrier's shield spring and make it unusable
  - Combining SAS and SATA hard drives in the same RAID volume is not supported.
1. Press the release button and slide the hard disk blank out of the hard drive slot.
  2. Install a hard drive in the hard drive carrier.
  3. Press the release button on the front of the hard drive carrier and open the hard drive carrier handle.
  4. Insert the hard drive carrier into the hard drive slot until the carrier connects with the backplane

# AXIS Camera Station S1148 Recorder

## Manage your device

---

5. Close the hard drive carrier handle to lock the hard drive in place.

### Add new drive to RAID array

#### ⚠CAUTION

Changing the RAID deletes all data from your disks.

1. Boot Lifecycle Controller:
  - 1.1 Power on your device.
  - 1.2 When you see the AXIS splash screen, press F10.
2. In the Lifecycle Controller, go to **Hardware Configuration > Configuration Wizards** and select **RAID Configuration**.
3. Select the **RAID Controller** on which you want to have the RAID created. Details of any virtual disk(s) available on the selected controller will be shown in the table displayed on the page below the controller list. *Foreign Configuration* will be displayed if there are any foreign or uninitialized HDD(s) available on the server.

#### Note

- Clear foreign configuration clears all the foreign HDDs available on the RAID controller selected.
  - Ignore foreign Configuration ignores the foreign HDDs available on the RAID controller while creating the RAID.
4. Clear or ignore foreign HDDs and uninitialized HDDs.

If you want, you can initialize the uninitialized disks:

    - 4.1 In the list of all non-RAID (uninitialized) HDDs, select the HDDs you want to convert to RAID capable (initialize) and click **Next** to initialize them.
    - 4.2 Select the corresponding option on the Configuration Wizards: RAID Configuration page.
  5. Select a RAID level. The default settings are:
    - S1148 24 TB: RAID 5
    - S1148 64 TB: RAID 5
    - S1148 140 TB: RAID 6
    - S1132: RAID 5
  6. Select the physical disks from the table and click **Next**.

If the you've selected **Ignore foreign configuration**, the foreign HDDs are not displayed in the table.
  7. Enter the virtual disk attributes.
  8. Click **Next**.
  9. Review the settings and click **Finish**.
  10. Lifecycle Controller displays a message to indicate that all the current data about the virtual disks available on the controller will be lost. Click **OK** to continue.
  11. Click **OK** and **Finish**.
  12. Exit the wizard and reboot the system.

### Configure Windows®

1. Right-click the Windows®-symbol at the Start menu and select **Disk Management**.

# AXIS Camera Station S1148 Recorder

## Manage your device

---

2. Go to **Action > All Tasks > Extend Volume**. The Extend Volume Wizard starts.
3. Click **Next**.
4. Select the disk that has unused space and click **Next**. Usually this disk is selected by the wizard.
5. Click **Finish**.

Disk Management now shows the extend volume and your system is ready to use the extended volume.

# AXIS Camera Station S1148 Recorder

## Troubleshooting

---

### Troubleshooting

#### Check the current BIOS version

When you troubleshoot a device, always check the current BIOS version. If your device doesn't have the latest version, we recommend to upgrade. The latest version may contain a correction that fixes your problem.

To check the current BIOS:

1. Power on the device.
2. Wait until you see the Axis splash screen. You'll see the version number above the splash screen.

#### Upgrade BIOS

We recommend to keep the BIOS up to date.

If you don't have access to Windows®: update package instructions for EFI

1. Go to the support pages on *dell.com* and enter your service tag. Go to **Drivers & Downloads** and download the .efi file.
2. Copy the file to a USB device.
3. Plug in the USB device and press F11 during POST to enter BIOS Boot Manager.
4. Go to **System Utilities menu > BIOS Update File Explorer**.
5. Select the USB device and navigate through the directory contents to find the executable (.efi).
6. Launch the executable and follow the instructions provided by the flash utility.

If you have access to Windows®: update package instructions for Windows® Dup

1. Browse to the location where you downloaded the file and double-click the new file.
2. Read over the release information in the dialog window.
3. Download and install any prerequisites identified in the dialog window before proceeding.
4. Install any necessary Embedded Systems Management firmware prior to this BIOS update.
5. Click **Install**.
6. Follow the onscreen instructions.

#### Run diagnostics

Running diagnostics help you to identify the cause for a system issue. The diagnostics test your system hardware without requiring additional equipment or risking data loss.

1. While the system is booting, press F11 to enter Boot Manager.  
Alternatively, press F10 to enter Lifecycle Controller.
3. Go to **Hardware Diagnostics** and click **Run Hardware Diagnostics**.
4. Note the error code and contact Axis technical support.

# AXIS Camera Station S1148 Recorder

## Troubleshooting

---

### Perform a system recovery

If the device has had a complete system failure, you must use a recovery image to recreate the Windows® system. To download the AXIS Recovery Kit, contact Axis technical support and supply the serial number of your device.

1. Download the AXIS Recovery Kit and AXIS ISO to USB Tool.
2. Insert a USB drive into your computer.
  - Use a USB drive with a minimum of 16 GB to 32 GB.
  - The USB drive will be formatted, and all existing data will be erased.
3. Run the AXIS ISO to USB Tool and follow the onscreen instructions.

Writing data to the USB drive takes approximately 10 to 15 min. Don't remove the USB drive until the process is complete.
4. After the ISO to USB tool is complete, take the USB drive and plug it into your device.
5. Start your device.
6. When you see the AXIS splash screen, press F11.
7. Click **One-shot UEFI Boot Menu**.
8. Navigate to your USB drive and press ENTER. The system boots into the AXIS Recovery Kit.
9. Click **Reinstall Operating System**.

The recovery takes roughly 10 to 15 min to complete. You find detailed instructions in the download for the recovery kit.

### Create a technical support report

The Export Tech Support Report feature allows you to export the technical support report to a USB drive or a network share (CIFS/NFS). In the report you can collect the following data:

- Hardware
- RAID controller logs

To create a technical support report:

1. During Power-on-self-test (POST), press F10 to start Lifecycle Controller.
2. Go to **Hardware Diagnostics > Export Tech Support Report**.
3. Read the terms and conditions and click **Next**.

You must accept the terms and conditions to allow technical support to use the technical support report data.
4. Select the data options which you want to include in the technical support report and click **Next**.
5. Enter the required export settings information and click **Next**.
  - To export the report to a USB drive: select the USB drive option and then select the name of the USB Drive and enter the file path details to where the report is to export.
  - To export the report to NFS: select the NFS option and enter the required information.
  - To export the report to CIFS: select the CIFS option and enter the required information.

Click **Test Network Connection** to verify if the Lifecycle Controller can connect to the IP address that is provided. By default, it pings the Gateway IP, DNS Server IP, host IP and Proxy IP.
6. Verify your selection and click **Finish**.

# AXIS Camera Station S1148 Recorder

## Troubleshooting

---

Lifecycle Controller retrieves the selected report data and exports the report file to the specified location. This can take a few minutes.

### Enable iDRAC

You can set up the IP address or use the default iDRAC IP address 192.168.0.120 to configure initial network settings, including setting up DHCP or the static IP for iDRAC. By default, the dedicated iDRAC network card is disabled. The iDRAC is sharing the network card on LOM 1 (LAN on Motherboard). In the case of blade servers, the iDRAC network interface is disabled by default.

To set up iDRAC IP using iDRAC settings utility:

1. Turn on the managed system.
2. Press F2 during Power-on Self-test (POST).
3. In the **System Setup Main Menu** page, click **iDRAC Settings**.
4. Click **Network**.
5. Enable NIC.
6. Specify the other network settings.
7. Click **Back**, **Finish**, and then **Yes**. The network information is saved and the system reboots.

You can open the iDRAC webpage from any supported browser. The default login information is:

- Username: root
  - Password: available on the back of the information tag.
8. After you configure iDRAC IP address, ensure that you change the default user name and password after setting up the iDRAC IP address.

#### Note

If there is any access issue:

- Try to ping the iDRAC IP to check that the network configuration has been replied.
- Check which LOM (network card) has been selected in the iDRAC network settings. The LOM can be shared with the server network cards or use the dedicated iDRAC NIC's.

### Troubleshoot the power supply unit

#### Note

After installing a power supply unit, allow several seconds for the system to recognize the power supply unit and determine if it the power supply works properly.

1. Ensure that no loose connections exist. For example, loose power cables.
2. Ensure that the power supply handle LED indicates that the power supply is working properly.
3. Check the status of the power indicator on the power supply unit.
  - If the power indicator is green, reset the power supply unit. If this does not fix the issue, test the system with a good power supply unit.
  - If the power indicator is amber, this indicates a power supply unit fault condition. Replace the power supply unit with a good power supply unit and check the indicator status.
  - If the issue is resolved, consider replacing the power supply unit.

# AXIS Camera Station S1148 Recorder

## Troubleshooting

---

4. If you have a redundant power supply configuration, ensure that both power supply units are of the same type and wattage. You may have to upgrade to a higher wattage PSU.
5. Ensure that you use only power supply units with the Extended Power Performance (EPP) label on the back.
6. Reset the power supply unit.
7. If the problem persists, contact Axis Technical Support.

### Troubleshoot memory errors

1. Upgrade the BIOS to the latest version.
2. If the errors persist, contact Axis technical support.

### Troubleshoot AXIS Camera Station

For information about how to troubleshoot AXIS Camera Station, go to the *AXIS Camera Station user manual*.



# AXIS Camera Station S1148 Recorder

## Product overview

### Product overview

#### Front and rear sides

S1148 24 TB

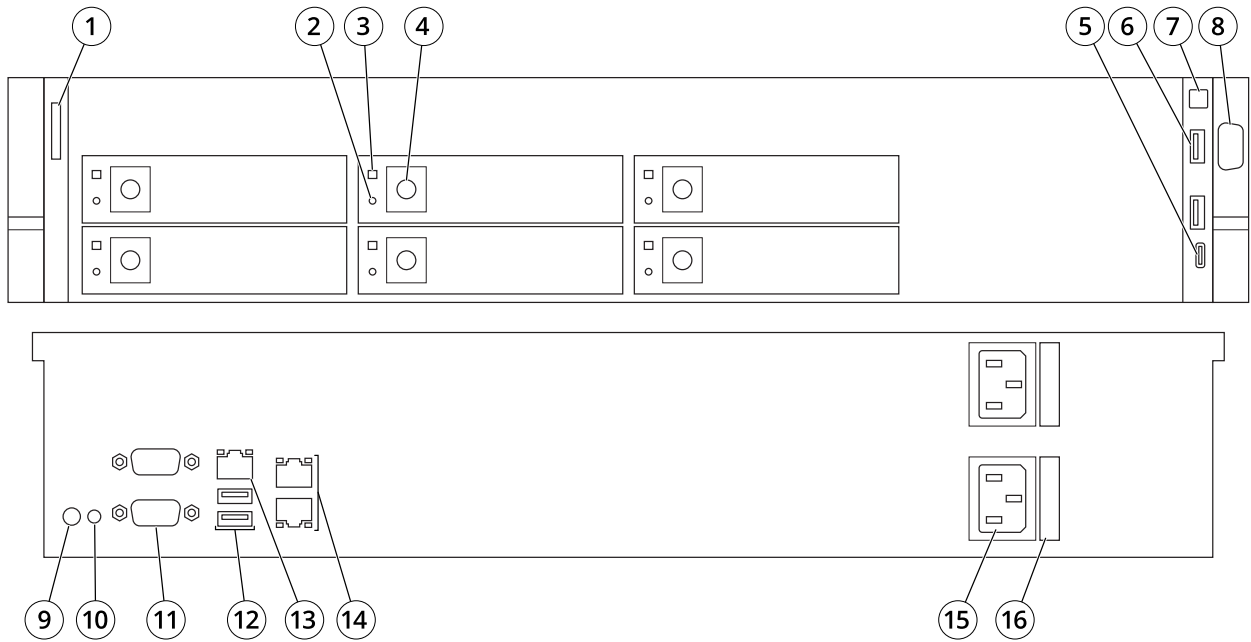

S1148 64 TB

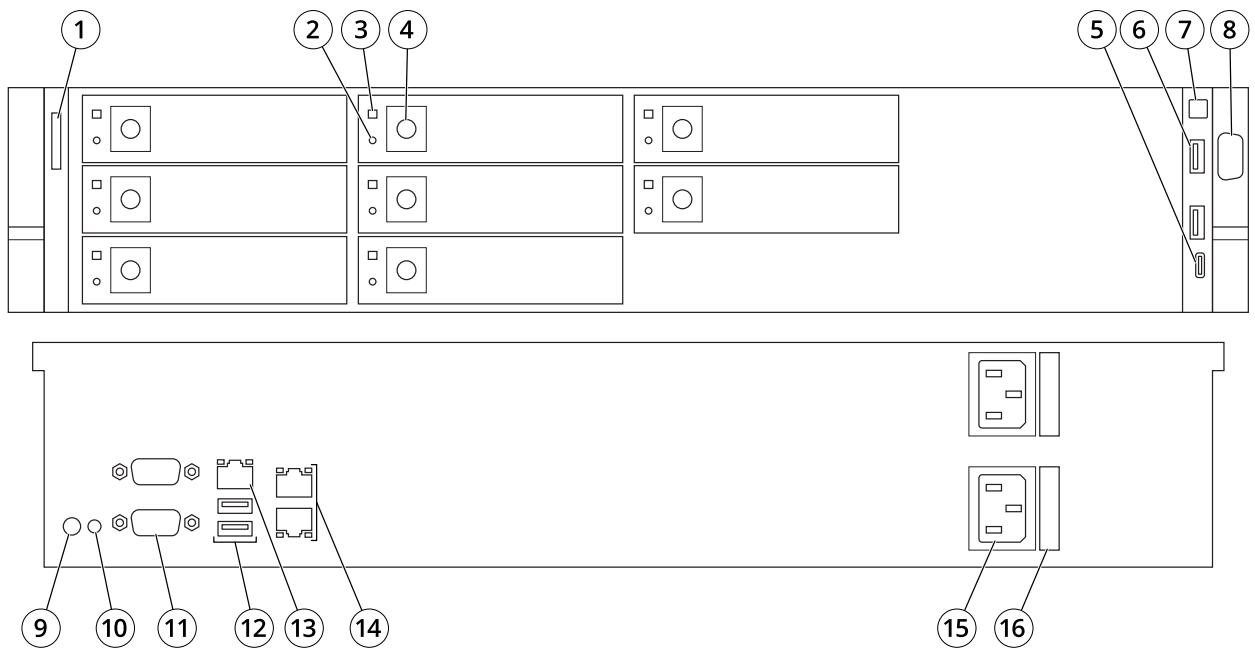

# AXIS Camera Station S1148 Recorder

## Product overview

S1148 140TB

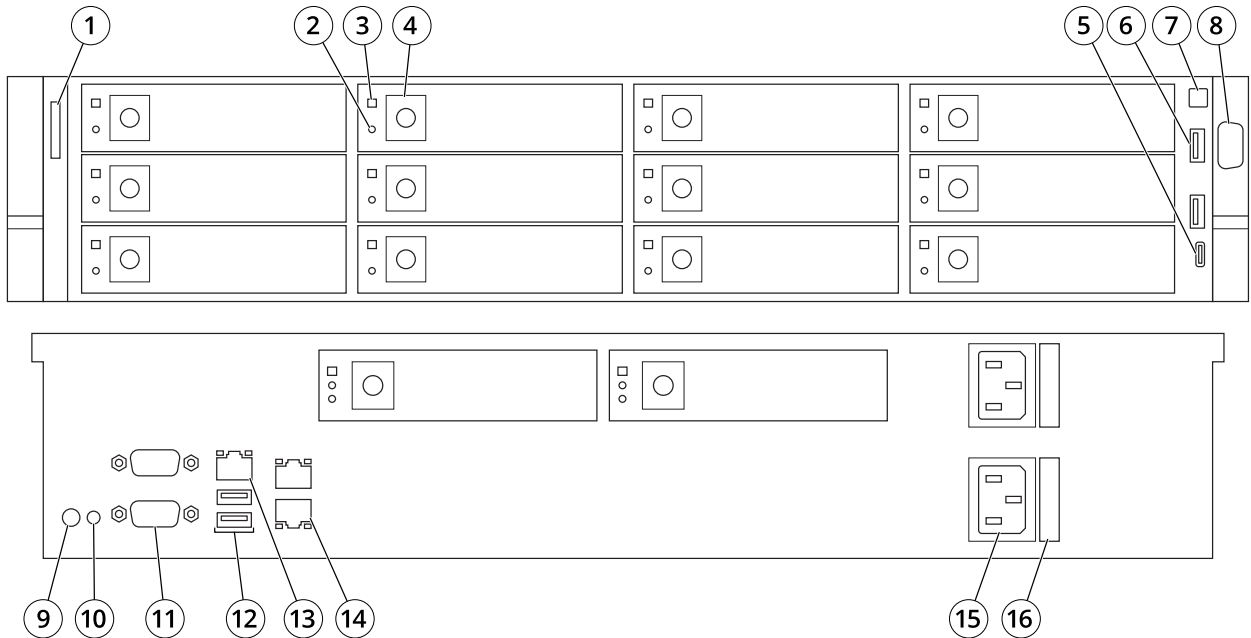

- 1 *i LED*
- 2 *Drive activity LED*
- 3 *Drive status LED*
- 4 *Opening button*
- 5 *USB 3.1 Type-C*
- 6 *USB 2.1*
- 7 *System power LED/power button*
- 8 *VGA*
- 9 *System identification button*
- 10 *System status indicator cable port*
- 11 *VGA*
- 12 *USB 3.1*
- 13 *iDRAC9 dedicated network port*
- 14 *Ethernet (RJ45) 1 GbE*
- 15 *Power connector*
- 16 *Power cable lock*

## Specifications

### System health and ID indicators

LED	Description	Action
Blue solid	The system is turned on, system is healthy and system ID mode is not active.	Press the system health and system ID button to switch to system ID mode.
Blue blinking	The system ID mode is active.	Press the system health and system ID button to switch to system health mode.

# AXIS Camera Station S1148 Recorder

## Product overview

Amber solid	The system is in fail-safe mode.	-
Amber blinking	The system is experiencing a fault.	Check the system event log for the specific error message.

### iDRAC quick sync 2 indicator

LED	Description	Action
Off (default state)	The iDRAC Quick Sync 2 feature is turned off.	Press the iDRAC Quick Sync 2 button to turn on the iDRAC Quick Sync 2 feature.If the LED fails to turn on, reset the left control panel flex cable and check again.
White solid	The iDRAC Quick Sync 2 is ready to communicate.	Press the iDRAC Quick Sync 2 button to turn off.If the LED fails to turn off, restart the system.
Blinks white rapidly	Data transfer activity	-
Blinks white slowly	Firmware update is in progress.	-
Blinks white five times rapidly and then turns off	The iDRAC Quick Sync 2 feature is disabled.	Check if iDRAC Quick Sync 2 feature is configured to be disabled by iDRAC.
Amber solid	The system is in fail-safe mode.	Restart the system.
Amber blinking	The iDRAC Quick Sync 2 hardware is not responding properly.	Restart the system.

### NIC indicators

LED	Description
Link and activity indicators are off	The NIC is not connected to the network.
Link indicator is green and activity indicator is blinking green	The NIC is connected to a valid network at its maximum port speed and data is being sent or received.
Link indicator is amber and activity indicator is blinking green	The NIC is connected to a valid network at less than its maximum port speed and data is being sent or received.
Link indicator is green and activity indicator is off	The NIC is connected to a valid network at its maximum port speed and data is not being sent or received.
Link indicator is amber and activity indicator is off	The NIC is connected to a valid network at less than its maximum port speed and data is not being sent or received
Link indicator is blinking green and activity is off	NIC identify is enabled through the NIC configuration utility.

### Power supply unit indicators

LED	Description
Green	A valid power source is connected to the PSU and the PSU is operational.
Blinking amber	Indicates a problem with the PSU
Not illuminated	Power is not connected.

# AXIS Camera Station S1148 Recorder

## Product overview

Blinking green	When the firmware of the PSU is being updated, the PSU handle blinks green. CAUTION: Do not disconnect the power cord or unplug the PSU when updating firmware. If firmware update is interrupted the PSUs do not function.
Blinking green and turns off	<p>When hot-plugging a PSU, the PSU handle blinks green five times at a rate of 4Hz and turns off. This indicates a PSU mismatch with respect to efficiency, features set, health status, or supported voltage.</p> <p><b>CAUTION</b></p> <ul style="list-style-type: none"> <li>• If two PSUs are installed, both the PSUs must have the same type of label. For example, Extended Power Performance (EPP) label. Mixing PSUs from previous generations of PowerEdge servers is not supported, even if the PSUs have the same power rating. This results in a PSU mismatch condition or failure to turn the system on.</li> <li>• When correcting a PSU mismatch, replace only the PSU with the blinking indicator. Swapping the PSU to make a matched pair can result in an error condition and unexpected system shutdown. To change from a high output configuration to a low output configuration or vice versa, you must turn off the system.</li> <li>• AC PSUs support both 240 V and 120 V input voltages with the exception of Titanium PSUs, which support only 240 V. When two identical PSUs receive different input voltages, they can output different wattages, and trigger a mismatch.</li> <li>• If two PSUs are used, they must be of the same type and have the same maximum output power.</li> <li>• Combining AC and DC PSUs is not supported and triggers a mismatch.</li> </ul>

### Power indicators

LED	Description
Green	A valid power source is connected to the PSU and the PSU is operational.
Blinking amber	Indicates a problem with the PSU.
Not illuminated	Power is not connected.
Blinking green	When hot-plugging a PSU, the PSU indicator blinks green. This indicates that there is a PSU mismatch with respect to efficiency, feature set, health status, or supported voltage.

# AXIS Camera Station S1148 Recorder

## Product overview

---

	<p><b>⚠ CAUTION</b></p> <ul style="list-style-type: none"><li>• When correcting a PSU mismatch, replace only the PSU with the blinking indicator. Swapping the PSU to make a matched pair can result in an error condition and unexpected system shutdown. To change from a High Output configuration to a Low Output configuration or vice versa, you must turn off the system.</li><li>• If two PSUs are used, they must be of the same type and have the same maximum output power.</li><li>• Combining AC and DC PSUs is not supported and triggers a mismatch.</li></ul>
--	---

### Hard drive indicators

LED	Description
Flashes green twice per second	Identifying drive or preparing for removal.
Off	Drive ready for insertion or removal. <b>Note</b> The drive status indicator remains off until all hard drives are initialized after the system is turned on. Drives are not ready for removal during this time.
Flashes green, amber and then turns off	Predicted drive failure.
Flashes amber four times per second	Drive has failed.
Flashes green slowly	Drive is rebuilding.
Steady green	Drive is online.
Flashes green for 3 s, amber for 3 s, and then turns off after 6 s	Rebuild stopped.

# AXIS Camera Station S1148 Recorder

## Need more help?

---

### Need more help?

#### Useful links

- *AXIS Camera Station user manual*
- *Configure Axis Secure Remote Access*
- *What to include in an Antivirus allowlist for AXIS Camera Station*

#### Contact support

If you need more help, go to [axis.com/support](https://axis.com/support).

