

AXIS Camera Station S9101 Mk II Desktop Terminal

User manual

AXIS Camera Station S9101 Mk II Desktop Terminal

Table of Contents

About your device	3
Get started	4
Install your device	5
Configure your device	10
First-time configuration	10
Log in to AXIS Camera Station server	10
Configure AXIS Camera Station	11
Manage Windows® user accounts	15
Create a user account	15
Create an administrator account	15
Create a local user group	15
Delete a user account	15
Change a user account's password	16
Create a password reset disk for a user account	16
Manage AXIS Camera Station user accounts	17
Configure user permissions	17
Add users or groups	17
User or group privileges	18
Manage your device	20
Update Windows®	20
Configure Windows update settings	20
Troubleshooting	22
Reset your device	22
Perform a system recovery	22
Troubleshoot AXIS Camera Station	22
Product overview	23
Front and rear sides	23
Specifications	23
Need more help?	25
Useful links	25
Contact support	25

AXIS Camera Station S9101 Mk II Desktop Terminal

About your device

About your device

AXIS Camera Station S9101 MK II Desktop Terminal is an easy-to-install desktop terminal for high-definition surveillance where space is limited. The terminal is preloaded with AXIS Camera Station client and all necessary software and is preconfigured to minimize installation time. With its slim form factor, AXIS Camera Station S9101 MK II complements Axis rack servers to create a high performing surveillance workstation. The terminal has validated and optimized hardware components and supports two monitors one of which can be 4K resolution.

AXIS Camera Station S9101 Mk II Desktop Terminal

Get started

Get started

The standard workflow to configure an AXIS Camera Station desktop terminal is:

1. *Install your device*
2. Configure Windows®. We recommend to:
 - Update Windows® to the latest version. See *Update Windows® on page 20*
 - Create a standard user account. See *Create a user account on page 15*
3. *First-time configuration on page 10*
4. Update AXIS Camera Station to the latest version.
 - If your system is online: open the AXIS Recorder Toolbox app and click **Update AXIS Camera Station**.
 - If your system is offline: go to *axis.com* and download the latest version.
5. *Log in to AXIS Camera Station server on page 10*

AXIS Camera Station S9101 Mk II Desktop Terminal

Install your device

Install your device

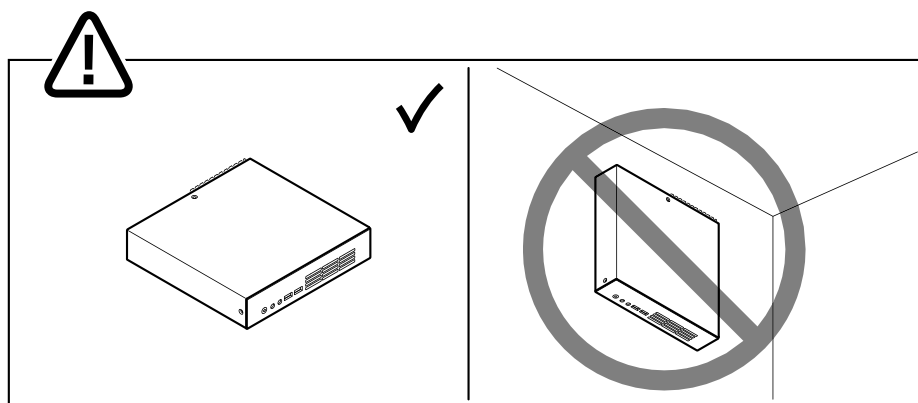
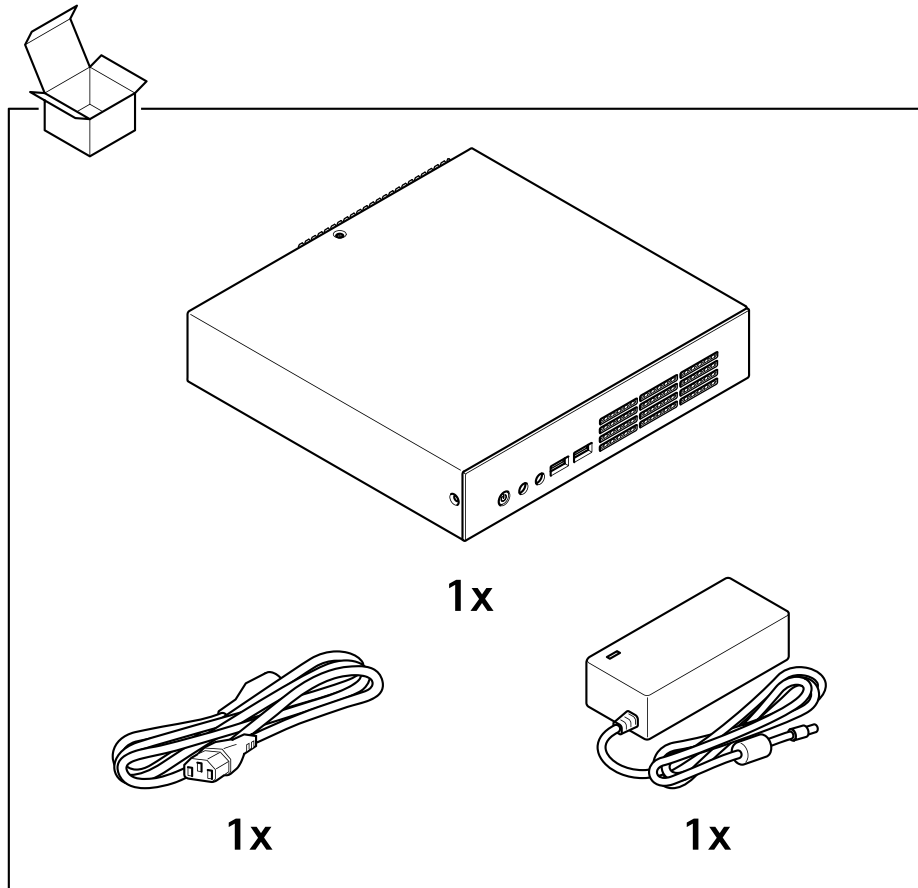

AXIS Camera Station S9101 Mk II Desktop Terminal

Install your device

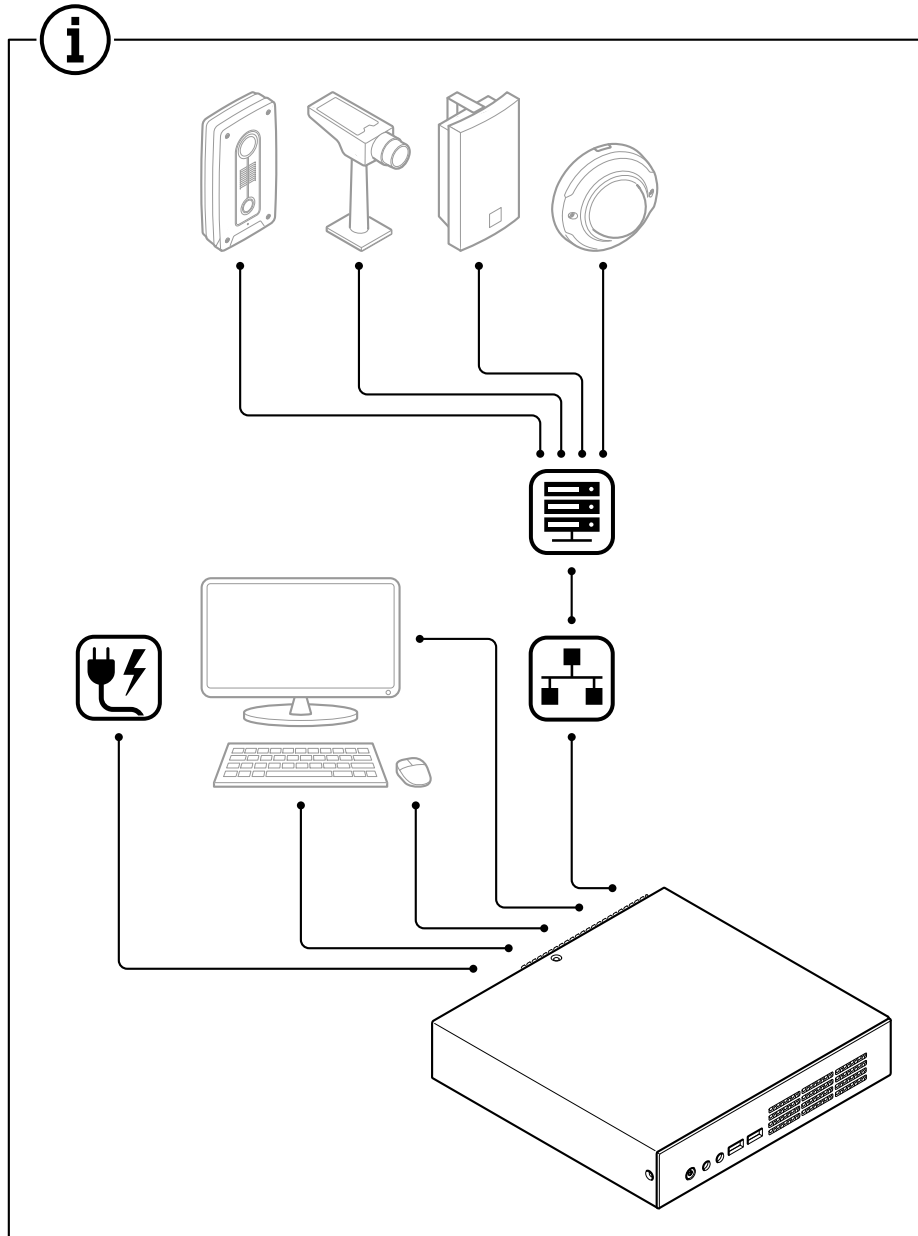

AXIS Camera Station S9101 Mk II Desktop Terminal

Install your device

1.1

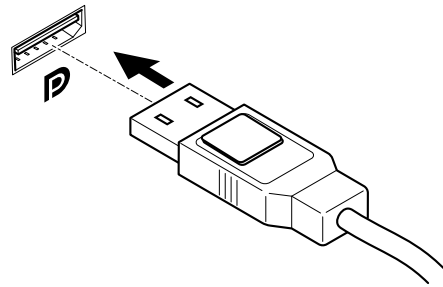
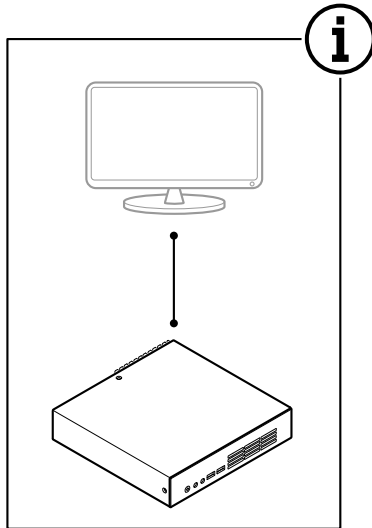

1.2

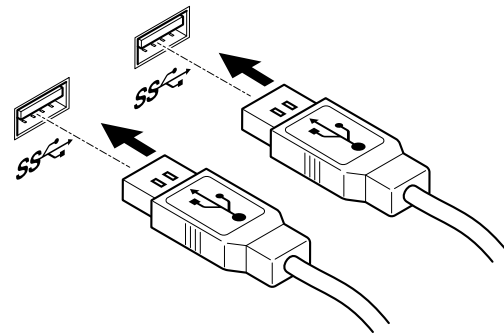
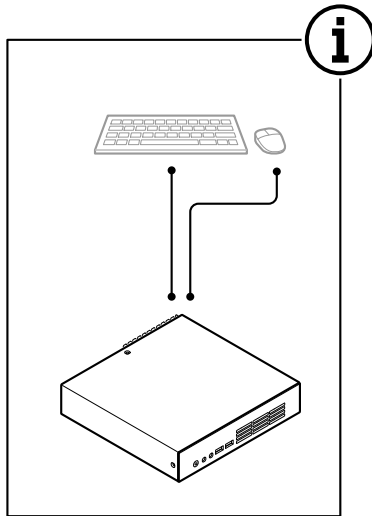

AXIS Camera Station S9101 Mk II Desktop Terminal

Install your device

1.3

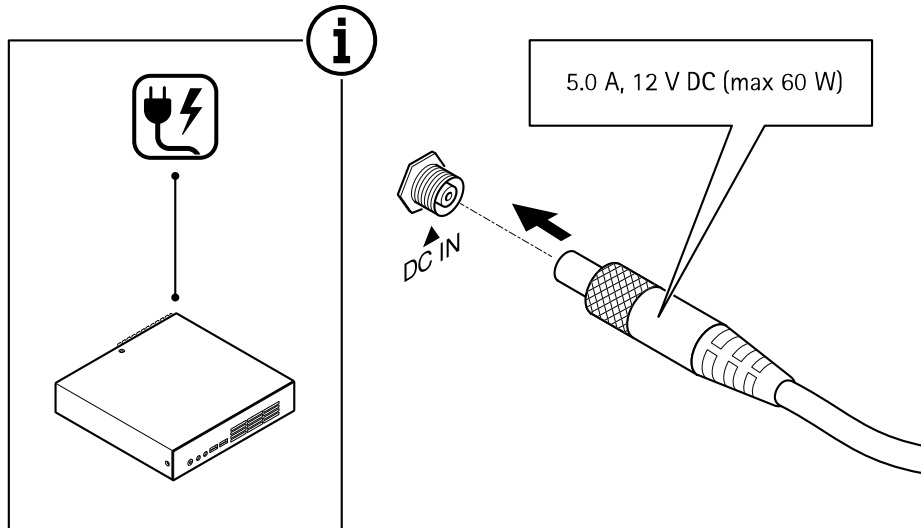

1.4

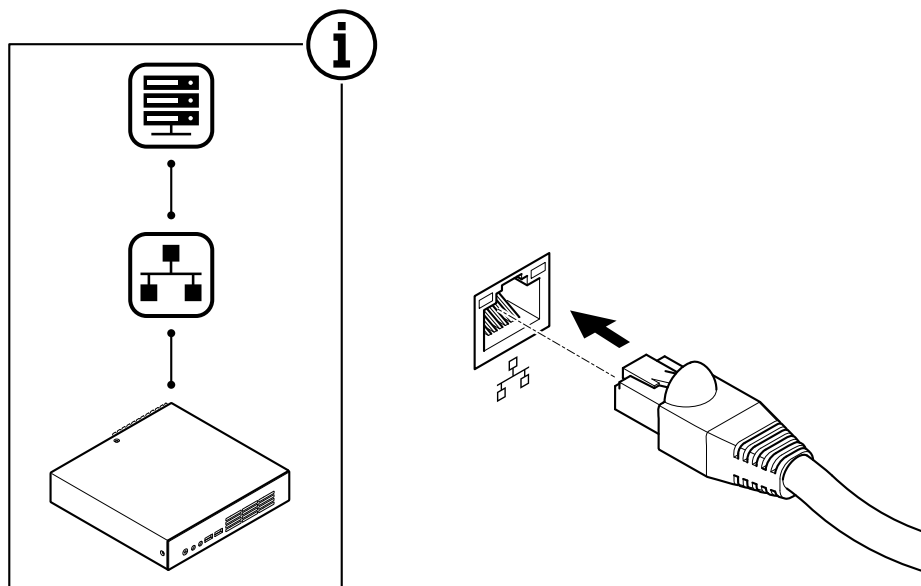

AXIS Camera Station S9101 Mk II Desktop Terminal

Install your device

1.5

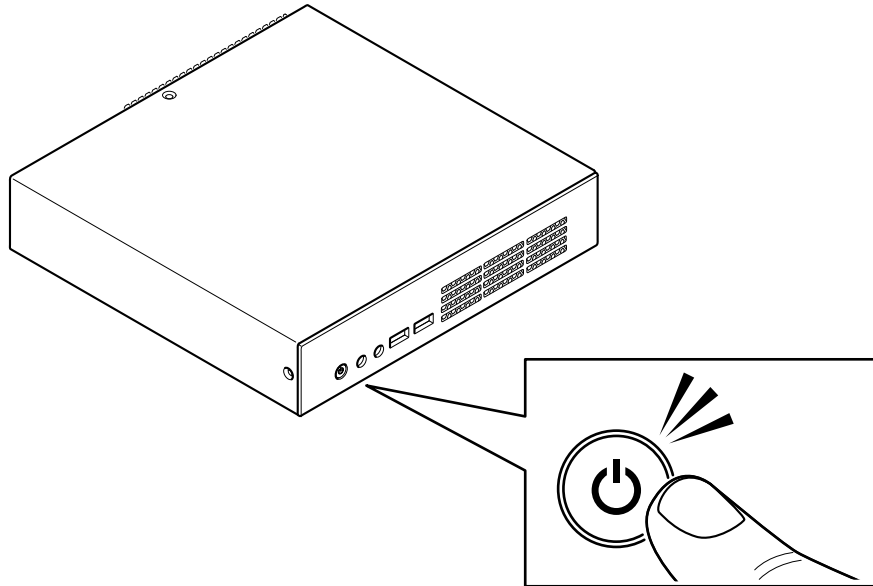

1.6

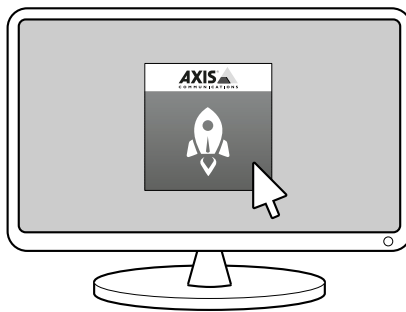

AXIS Camera Station S9101 Mk II Desktop Terminal

Configure your device

Configure your device

Note

This section describes how to configure the AXIS Camera Station client and server. Some of the instructions may not be relevant for your device.

First-time configuration



To watch this video, go to the web version of this document.
help.axis.com/?Etpiald=59519&tsection=first-time-configuration

After you have configured Windows®, AXIS Recorder Toolbox is opened automatically and you are guided through the first-time configuration wizard. In this wizard, you can configure several basic and necessary settings before you manage your device in AXIS Recorder Toolbox.

1. Change the computer name if you want and click **Next**.
2. Under **Date and time**, configure the following settings and click **Next**.
 - Select a time zone.
 - To set up an NTP server, select **NTP server** and enter the NTP server address.
 - To set manually, select **Manual** and select a date and time.
3. Under **Network settings**, configure the following settings and click **Next**.
 - **Use automatic IP settings (DHCP)** and **Use automatic DNS settings** are turned on by default.
 - If your device is connected to a network with a DHCP server, the assigned IP address, subnet mask, gateway, and preferred DNS are automatically displayed.
 - If your device is not connected to a network or there is no DHCP server available, enter the IP address, subnet mask, gateway, and preferred DNS manually depending on the network requirements.
4. Under **Power settings**,
 - **Never put the computer to sleep** and **Never turn off the display** are selected by default.
 - We recommend that you keep both options selected to make the live view and recordings available all the time. You can always go to **Start > Settings > System > Power & sleep** to change the settings.
5. Click **Finish**. If you have changed the computer name, AXIS Recorder Toolbox will prompt you to restart the device.

Log in to AXIS Camera Station server

Using the AXIS Camera Station client, you can connect to multiple servers or a single server installed on the local computer or somewhere else on the network. You can connect to AXIS Camera Station servers in different ways:

AXIS Camera Station S9101 Mk II Desktop Terminal

Configure your device

Last used servers – Connect to the servers used in the previous session.

This computer – Connect to the server installed on the same computer as the client.

Remote server – See *Log in on a remote server on page 11*.

AXIS Secure Remote Access – See *Sign in to AXIS Secure Remote Access on page 11*.

Note

When trying to connect to a server for the first time, the client checks the server certificate ID. To ensure that you're connecting to the correct server, manually verify the certificate ID with the one displayed in AXIS Camera Station Service Control.

To connect to servers from a server list, select a one from the **Server list** drop-down menu. Click  to create or edit the server lists.

To import a server list file exported from AXIS Camera Station, click **Import server list** and browse to an .msl file.

To delete saved usernames and passwords all connected servers, click **Delete saved passwords**.

You might need to change the client proxy settings to connect to a server, click **Change client proxy settings**.

Log in on a remote server

1. Select **Remote server**.
2. Select a server from the **Remote server** drop-down list or enter the IP or DNS address in the field. If the server is not listed, click  to reload all the available remote servers. If the server is configured to accept clients on a different port than the default port number 55752, enter the IP address followed by the port number, for example, 192.168.0.5:46001
3. You can:
 - Select **Log in as current user** to log in as the current Windows user.
 - Clear **Log in as current user** and click **Log in**. Select **Other user** and provide another username and password to log in with a different username and password.
 - Select **Log in as <username>** if you have your username and password remembered.

Sign in to AXIS Secure Remote Access

Note

When trying to connect to a server using Axis Secure Remote Access, the server can't upgrade the client automatically.

1. Click the **Sign in to AXIS Secure Remote Access** link.
2. Enter your MyAxis account credentials.
3. Click **Sign in** and **Grant** to grant access.

Configure AXIS Camera Station

This Get started tutorial will walk you through the basic steps to make your system up and running.

Before you start, you may need to:

- Configure your network depending on your installation. See *Network configuration*.
- Configure your server ports if needed. See *Server port configuration*.

AXIS Camera Station S9101 Mk II Desktop Terminal

Configure your device

- Consider security issues. See *Security considerations*.

After necessary configurations, you can start to work with AXIS Camera Station:

1. *Start AXIS Camera Station*
2. *Add devices*
3. *Configure recording method on page 12*
4. *View live video on page 12*
5. *View recordings on page 12*
6. *Add bookmarks on page 13*
7. *Export recordings on page 13*
8. *Play and verify recordings in AXIS File Player on page 13*

Start AXIS Camera Station

Double-click the AXIS Camera Station client icon to start the client. When you start the client for the first time, it attempts to log in to the AXIS Camera Station server installed on the same computer as the client.

You can connect to multiple AXIS Camera Station servers in different ways.

Add devices

The Add devices page opens the first time you start AXIS Camera Station. AXIS Camera Station searches the network for connected devices and shows a list of devices found.

1. Select the cameras you want to add from the list. If you can't find your camera, click **Manual search**.
2. Click **Add**.
3. Select **Quick configuration** or **Site Designer configuration**. Click **Next**.
4. Use the default settings and ensure the recording method is **None**. Click **Install**.

Configure recording method

1. Go to **Configuration > Recording and events > Recording method**.
2. Select a camera.
3. Turn on **Motion detection**, or **Continuous**, or both.
4. Click **Apply**.

View live video

1. Open a **Live view** tab.
2. Select a camera to view its live video.

See for more information.

View recordings

1. Open a **Recordings** tab.
2. Select the camera you want to view recordings from.

AXIS Camera Station S9101 Mk II Desktop Terminal



Configure your device

See for more information.

Add bookmarks

1. Go to the Recording tab.
2. In the timeline of the camera, use the mouse wheel to zoom in and out and drag the timeline to make the marker pointing at your desired position.
3. Click  .
4. Enter the bookmark name and description. Use keywords in the description to make the bookmark easy to find and recognized.
5. Select **Prevent recording deletion** to lock the recording. A locked recording can't be deleted unless actively unlocked.
6. Click **OK**. A bookmark icon is displayed at your desired position in the timeline.

Export recordings

1. Open a Recordings tab.
2. Select the camera you want to export recordings from.
3. Click  to display the selection markers.
4. Drag the markers to include the recordings that you want to export.
5. Click  to open the Export tab.
6. Click **Export...**

Play and verify recordings in AXIS File Player

1. Go to the folder with the exported recordings.
2. Double-click AXIS File Player.
3. Click  to show the recording's notes.
4. To verify the digital signature:
 - 4.1 Go to **Tools > Verify digital signature**.
 - 4.2 Select **Validate with password** and enter your password.
 - 4.3 Click **Verify**. The verification result page appears.

Note

Digital signature is different from Signed video. Signed video allows you to trace video back to the camera it came from, making it possible to verify that the recording wasn't tampered with. See *Signed video* and the camera's user manual for more information.

Network configuration

When AXIS Camera Station client, AXIS Camera Station server, and the connected network devices are installed on different networks, you might need to configure proxy or firewall settings before using AXIS Camera Station.

Client proxy settings

AXIS Camera Station S9101 Mk II Desktop Terminal

Configure your device

When the client and the server are separated by a proxy server, configure the client proxy settings.

1. Double-click the AXIS Camera Station client icon.
2. Click **Change client proxy settings**.
3. Change the client proxy settings.
4. Click **OK**.

Server proxy settings

When network devices and the server are separated by a proxy server, configure the server proxy settings.

1. Double-click the AXIS Service Control icon in Windows notification area.
2. Select **Modify settings**.
3. In the Proxy settings section, use the default **System account internet option** or select **Use manual proxy settings**.
4. Click **Save**.

NAT and Firewall

When the client and the server are separated by a NAT, firewall or similar, configure the NAT or firewall to ensure that the HTTP port, TCP port, and streaming port specified in AXIS Camera Station Service Control are allowed to pass through the firewall and/or NAT. For instructions how to configure the NAT or firewall, contact the network administrator.

Server port configuration

AXIS Camera Station server uses ports 55752 (HTTP), 55754 (TCP), 55756 (mobile communication), and 55757 (mobile streaming) for communication between the server and the client. You can change the ports in AXIS Camera Station Service Control if required. See **General** in AXIS Camera Station Service Control.

Security considerations

To prevent unauthorized access to cameras and recordings, keep the following in mind:

- Use strong passwords for all network devices (cameras, video encoders, and auxiliary devices).
- Install AXIS Camera Station server, cameras, video encoders, and auxiliary devices on a secure network separate from the office network. You can install the AXIS Camera Station client on a computer on another network, for example, a network with internet access.
- Make sure all users have strong passwords. Windows Active Directory provides a high level of security.

AXIS Camera Station S9101 Mk II Desktop Terminal

Manage Windows® user accounts

Manage Windows® user accounts

Create a user account

To help keep your personal data and information more secure, we recommend that you add a password for each local account.

Important

Once you create a password for a local account, don't forget it. There's no way to recover a lost password for local accounts.

1. Go to **Settings > Accounts > Other people > Add someone else to this PC**.
2. Click **I don't have this person's sign-in information**.
3. Click **Add a user without a Microsoft account**.
4. Enter a user name, password and password hint.
5. Click **Next** and follow the instructions.

Create an administrator account

1. Go to **Settings > Accounts > Other people**.
2. Go to the account you want to change and click **Change account type**.
3. Go to **Account type** and select **Administrator**.
4. Click **OK**.
5. Restart your device and sign in with the new administrator account.

Create a local user group

1. Go to **Computer Management**.
2. Go to **Local Users and Groups > Group**.
3. Right-click **Group** and select **New Group**.
4. Enter a group name and a description.
5. Add group members:
 - 5.1 Click **Add**.
 - 5.2 Click **Advanced**.
 - 5.3 Find the user account(s) you want to add to the group and click **OK**.
 - 5.4 Click **OK** again.
6. Click **Create**.

Delete a user account

Important

When you delete an account you remove the user account from the login screen. You also remove all files, settings and program data stored on the user account.

AXIS Camera Station S9101 Mk II Desktop Terminal

Manage Windows® user accounts

1. Go to **Settings > Accounts > Other people**.
2. Go to the account you want to remove and click **Remove**.

Change a user account's password

1. Log in with an administrator account.
2. Go to **User Accounts > User Accounts > Manage another account in sequence**.
You'll see a list with all user accounts on the device.
3. Select the user account whose password you would like to change.
4. Click **Change the password**.
5. Enter the new password and click **Change password**.

Create a password reset disk for a user account

We recommend to create a password reset disk using a USB flash drive. Then, if you forget your password, you can reset the password. Without a USB reset disk, you can't reset the password.

If you're using Windows 10, you can add security questions to your local account in case you forget your password, so you don't need to create a password reset disk. To do this, go to **Start** and click **Settings > Sign-in options > Update your security questions**.

1. Sign in to your device with a local user account. You can't create a password reset disk for a connected account.
2. Plug a USB flash drive into your device.
3. If there's any data on the USB flash drive, back it up.
4. From the Windows® search field, go to **Create a password reset disk**.
5. In the Forgotten Password wizard, click **Next**.
6. Select your USB flash drive and click **Next**.
7. Type your current password and click **Next**.
8. Follow the onscreen instructions.
9. Remove the USB flash drive and keep it in a safe place where you'll remember it. You don't have to create a new disk when you change your password even if you change it several times.

AXIS Camera Station S9101 Mk II Desktop Terminal

Manage AXIS Camera Station user accounts

Manage AXIS Camera Station user accounts

Configure user permissions

Go to **Configuration > Security > User permissions** to view a list of the users and groups that have been added to AXIS Camera Station.

Note

Administrators of the computer on which the AXIS Camera Station server is installed are automatically given administrator privileges to AXIS Camera Station. You can't change or remove the administrators group's privileges.

Before a user or group can be added, the user or group must be registered on the local computer or have an Windows Active Directory user account. Using Windows Active Directory, a high level of security can be implemented.

When a user is part of a group, the user gets the highest role permission that is assigned to the individual and the group.

When a user is part of a group, the user gets the access granted as an individual and also receives the rights as part of a group. For example, a user is given access to camera X as an individual. The user is also a member of a group. The group is given access to cameras Y and Z. The user then has access to cameras X, Y and Z.

If there are security concerns regarding the access to the computer by a designated AXIS Camera Station user, create a standard user account that you then use for access to Axis Camera Station. You can then elevate the account to administrator in **Configuration > Security > User permissions**.

The list consists of the following information:

Item	Description
Icon	Indicates the entry is a group or a single user.
Name	Username as it appears in the local computer or Active Directory.
Domain	Domain name where the user or group is registered.
Role	The access role given to the user or group. Possible values: Administrator, Operator, and Viewer.
Details	Detailed user information as it appears in the local computer or Active Directory.
Server	Server name where the user or group is registered. Only available when connecting to multiple AXIS Camera Station servers.

To add users or groups, see *Add users or groups*.

To change user access rights for a user or group, click the user or group and make changes. Click **Apply**.

To remove a user or group, select the user or group and click **Remove**. In the pop-up dialog, click **OK** to remove the user or group.

Add users or groups

User accounts in Microsoft Windows and Active Directory users and groups can access AXIS Camera Station. To add a user to AXIS Camera Station, you have to add users or a group to Windows.

To add a user or group in Microsoft Windows: Adding a user in Windows may vary depending on which version of Windows you are running. Follow the instructions on *Microsoft's site*. If you are connected to an Active Directory domain network, consult your network administrator.

Add users or groups

1. Go to **Configuration > Security > User permissions** and click **Add**.

AXIS Camera Station S9101 Mk II Desktop Terminal

Manage AXIS Camera Station user accounts

2. When connecting to multiple AXIS Camera Station servers, select a server from the **Selected server** drop-down list.
3. Select **Server** to search for users or groups on the local computer, or select **Domain** to search for Active Directory users or groups. When connecting to multiple AXIS Camera Station servers, you can select which server to search for.
4. Select **Users** or **Groups** to search for only users or groups.
5. The list of users or groups is displayed. Users and groups that have already been added to AXIS Camera Station are not listed.
 - If there are too many users or groups, the search result is not displayed. Use the **Type to search** field to refine the search and find a specific user or group.
 - If the domain user search fails, the **Service logon account** must be changed.
6. Select the users or groups and click **Add**. The users or groups are added to the list and shown in italics.

Configure a user or group

1. Select a user or group in the list.
2. Under **Role**, select **Administrator**, **Operator**, or **Viewer**.
3. If you have selected **Operator** or **Viewer**, you can configure the user or group privileges. See *User or group privileges*.
4. Click **Save**. The user or group in the list is not in italics and ready to be used.

User or group privileges

There are three roles that can be given to a user or group. For how to define access privileges for a user or group, see *Add users or groups*.

- **Administrator:** Full access to the entire system, including access to live and recorded video of all cameras, access to all I/O ports and views. Therefore, you do not need to specify any camera, I/O or view privileges for a user with this role. This role is required in order to configure anything in the system.
- **Operator:** Access to live and recorded video of selected cameras and access to selected I/O ports and views. An operator has full access to all functionality of AXIS Camera Station except system configuration.
- **Viewer:** Access to live video of selected cameras and access to selected I/O ports and views. A viewer does not have access to recorded video or system configuration.

Cameras

The following access privileges are available for users or groups with the Operator or Viewer role.

- **Access:** Allow access to the camera and all camera features.
- **Video:** Allow access to live video from the camera.
- **Audio listen:** Allow access to listen from the camera.
- **Audio speak:** Allow access to speak to the camera.
- **Manual Recording:** Allow to start and stop recordings manually.
- **Mechanical PTZ:** Allow access to mechanical PTZ controls. Only available for cameras with mechanical PTZ.
- **PTZ priority:** Set the PTZ priority. A lower number means a higher priority. 0 means that no priority is assigned. An administrator has the highest priority. When a role with higher priority operates a PTZ camera, others can't operate the same camera for 10 seconds by default. Only available for cameras with mechanical PTZ and **Mechanical PTZ** is selected.

Views

AXIS Camera Station S9101 Mk II Desktop Terminal

Manage AXIS Camera Station user accounts

The following access privileges are available for users or groups with the Operator or Viewer role. You can select multiple views and set the access privileges.

- **Access:** Allow access to the views in AXIS Camera Station.
- **Edit:** Allow to edit the views in AXIS Camera Station.

I/O

The following access privileges are available for users or groups with the Operator or Viewer role. The I/O ports are listed by device.

- **Access:** Allow full access to the I/O port.
- **Read:** Allow to view the state of the I/O port. The user is not able to change the port state.
- **Write:** Allow to change the state of the I/O port.

System

The access privileges that can't be configured are greyed out and listed under **Role privileges**. The privileges with check mark means the user or group have this privilege by default.

The following access privileges are available for users or groups with the Operator role.

- **Take snapshots:** Allow taking snapshots in the live view and recordings modes.
- **Export recordings:** Allow exporting recordings.
- **Generate incident report:** Allow generating incident reports.
- **Prevent access to recordings older than:** Prevent accessing recordings older than the specified number of minutes. When using search, the user will not find recordings older than the specified time. Recordings and bookmarks older than the specified time can't be played.
- **Access System Health Monitoring:** Allow accessing System Health Monitoring.

The following access privileges are available for users or groups with the Viewer role.

- **Take snapshots:** Allow taking snapshots in the live view and recordings modes.

Access control

The following access privileges are available for users or groups with the Operator role.

- **Access control configuration:** Allow configuration of doors and zones, identification profiles, card formats and PIN, encrypted communication, and multi server.
- **Access management:** Allow access management and access to the active directory settings.

The following access privileges are available for users or groups with the Viewer role.

- **Access management:** Allow access management and access to the active directory settings.

AXIS Camera Station S9101 Mk II Desktop Terminal

Manage your device

Manage your device

Important

By default, your Windows® system goes to sleep and the screen turns off after a certain time. To make the live view and recordings available all the time, go to **Start > Settings > System > Power & sleep** to change the settings.

Update Windows®

Windows® 10 periodically checks for updates. When an update is available, your device automatically downloads the update but you've to install it manually.

Note

Recording will be interrupted during a scheduled system restart.

To manually check for updates:

1. Go to **Settings > Update & Security > Windows Update**.
2. Click **Check for updates**.

Configure Windows update settings

Sometimes you might want to change how and when Windows® updates.

Note

All ongoing recordings stop during a scheduled system restart.

1. Open the Run app.
 - Go to **Windows System > Run**, or
 - press **WIN** and **R**.
2. Type `gpedit.msc` and click **OK**. The Local Group Policy Editor opens.
3. Go to **Computer Configuration > Administrative Templates > Windows Components > Windows Update**.
4. Configure the settings as required, see example.

Example

To automatically download and install updates without any user interaction and have the device restart if necessary out of office hours use the following configuration:

1. Open **Always automatically restart at the scheduled time** and select:
 - 1.1 **Enabled**
 - 1.2 **The restart timer will give users this much time to save their work (minutes): 15.**
 - 1.3 **Click OK.**
2. Open **Configure Automatic Updates** and select:
 - 2.1 **Enabled**
 - 2.2 **Configure Automatic updates: Auto download and schedule the install**
 - 2.3 **Schedule Install day: Every Sunday**

AXIS Camera Station S9101 Mk II Desktop Terminal

Manage your device

- 2.4 Schedule Install time: 00:00
 - 2.5 Click OK.
3. Open Allow Automatic Updates immediate installation and select:
 - 3.1 Enabled
 - 3.2 Click OK.

AXIS Camera Station S9101 Mk II Desktop Terminal

Troubleshooting

Troubleshooting

Reset your device

You can use the reset button to reset your device to factory default. It will take more than one hour to reset your device.

1. Power off your device.
2. Press and hold the reset button for 5 seconds. Windows RE will be started.
3. Select **Troubleshoot**.
4. Select **Reset your PC**.
5. Select **Keep my files** or **Remove everything**. If you select **Keep my files**, you need to provide the administrator credentials.
6. Follow the instructions on the screen.
7. The device reboots and starts the procedure to restore Windows to factory default.

Perform a system recovery

External recovery

If the device has had a complete system failure, you must use a recovery image to recreate the Windows® system. To download the AXIS Recovery Kit, contact AXIS Technical Support and supply the serial number of your device.

1. Download the AXIS Recovery Kit and AXIS ISO to USB Tool.
2. Insert a USB drive into your computer.
 - Use a USB drive with a minimum of 16 GB to 32 GB.
 - The USB drive will be formatted, and all existing data will be erased.
3. Run the AXIS ISO to USB Tool and follow the onscreen instructions.

Writing data to the USB drive takes approximately 10 to 15 min. Don't remove the USB drive until the process is complete.
4. After the ISO to USB tool is complete, take the USB drive and plug it into your device.
5. Start your device and before the AXIS splash screen appears press F12. We recommend that you tap the F12 key repeatedly as the device boots fast.
6. Navigate to your USB drive and press ENTER. The system boots into the AXIS Recovery Kit.

For example it should say **UEFI: Sandisk**.
7. Click **Reinstall Operating System**.

The recovery takes roughly 10 to 15 min to complete. You find detailed instructions in the download for the recovery kit.

Troubleshoot AXIS Camera Station

For information about how to troubleshoot AXIS Camera Station, go to the *AXIS Camera Station user manual*.

AXIS Camera Station S9101 Mk II Desktop Terminal

Product overview

Product overview

Front and rear sides

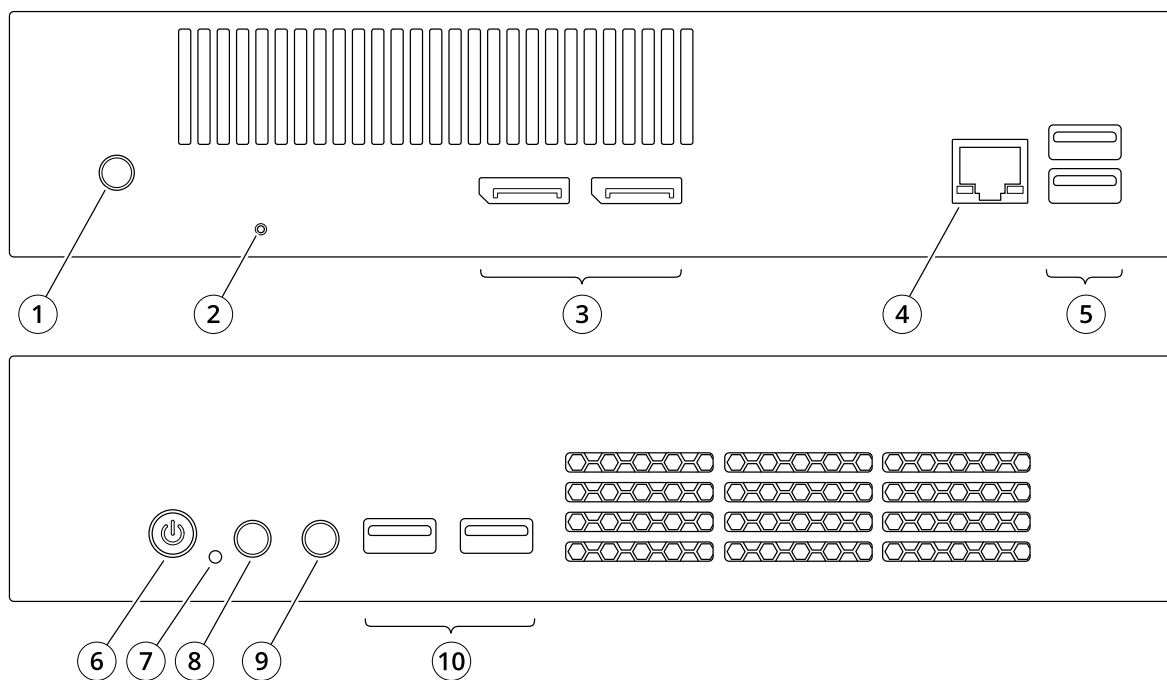

- 1 Power connector
- 2 Reset button
- 3 DisplayPort™ 1.2
- 4 Ethernet (RJ45) 1 GbE
- 5 USB 3.1
- 6 Power button
- 7 HDD LED
- 8 Audio line in
- 9 Audio line out
- 10 USB 3.1

AXIS Camera Station S9101 Mk II Desktop Terminal

Product overview

Specifications

LED indicator	Color	Description
Power	Steady white	Power on
Hard drive	White blinking	Hard drive activity

AXIS Camera Station S9101 Mk II Desktop Terminal

Need more help?

Need more help?

Useful links

- *AXIS Camera Station user manual*
- *Configure Axis Secure Remote Access*
- *What to include in an Antivirus allowlist for AXIS Camera Station*

Contact support

Contact support at axis.com/support.

