

AXIS T61 Mk II Audio and I/O Interface Series

AXIS T6101 Mk II Audio and I/O Interface

AXIS T6112 Mk II Audio and I/O Interface

User manual

AXIS T61 Mk II Audio and I/O Interface Series

Table of Contents

Installation	3
Configure your device	4
About the device	4
Set up rules for events	4
Audio	6
Specifications	8
Product overview	8
Solution overview	9
LED indicators	9
Connectors	10
Troubleshooting	12
Technical issues, clues and solutions	12
Contact support	12

AXIS T61 Mk II Audio and I/O Interface Series

Installation

Installation



To watch this video, go to the web version of this document.

help.axis.com/?Etpiald=78844&tsection=install

How to install AXIS T6101 Mk II Audio and I/O Interface



To watch this video, go to the web version of this document.

help.axis.com/?Etpiald=78844&tsection=install

How to install AXIS T6112 Mk II Audio and I/O Interface

AXIS T61 Mk II Audio and I/O Interface Series

Configure your device

Configure your device

About the device

When you connect your device to a supported Axis camera, settings for audio and I/O will appear on the camera's webpage.

Note

Make sure Link-Local address (ZeroConf) and IPv4 network protocols are turned on. Otherwise audio and I/O won't work.

You can manage all the settings described in this manual through the camera's webpage.

Set up rules for events

To learn more, check out our guide *Get started with rules for events*.

Trigger an action

1. Go to **System > Events** and add a rule. The rule defines when the device will perform certain actions. You can set up rules as scheduled, recurring, or manually triggered.
2. Enter a **Name**.
3. Select the **Condition** that must be met to trigger the action. If you specify more than one condition for the rule, all of the conditions must be met to trigger the action.
4. Select which **Action** the device should perform when the conditions are met.

Note

If you make changes to an active rule, the rule must be turned on again for the changes to take effect.

Provide visual indication of an ongoing event

You have the option to connect the **AXIS I/O Indication LED** to your network camera. This LED can be configured to turn on whenever certain events occur in the camera. For example, to let people know that video recording is in progress.



Required hardware

- **AXIS I/O Indication LED**
- **An Axis network video camera**

Note

For instructions on how to connect the **AXIS I/O Indication LED**, see the installation guide provided with the product.

The following example shows how to configure a rule that turns on the **AXIS I/O Indication LED** to indicate that camera is recording.

1. Go to **System > Accessories > I/O ports**.
2. For the port that you connected the **AXIS I/O Indication LED** to, click  to set the direction to **Output**, and click  to set the normal state to **Circuit open**.
3. Go to **System > Events**.
4. Create a new rule.

AXIS T61 Mk II Audio and I/O Interface Series

Configure your device

5. Select the **Condition** that must be met to trigger the camera to start recording. It can, for example, be a time schedule or motion detection.
6. In the list of actions, select **Record video**. Select a storage space. Select a stream profile or create a new. Also set the **Prebuffer** and **Postbuffer** as required.
7. Save the rule.
8. Create a second rule and select the same **Condition** as in the first rule.
9. In the list of actions, select **Toggle I/O while the rule is active**, and then select the port the AXIS I/O Indication LED is connected to. Set the state to **Active**.
10. Save the rule.

Other scenarios where AXIS I/O Indication LED can be used are for example:

- Configure the LED to turn on when the camera starts, to indicate the presence of the camera. Select **System ready** as a condition.
- Configure the LED to turn on when live stream is active to indicate that a person or a program is accessing a stream from the camera. Select **Live stream accessed** as a condition.

Open the lock to a gate when someone is nearby

This example explains how to direct the camera and open a gate when someone wants to enter during daytime. This is done by connecting a PIR detector to the product's input port and a switch relay to the product's output port.

Required hardware

- Mounted PIR detector
- Switch relay connected to the gate lock, in this case the switch is normally closed (NC)
- Connecting wires



Physical connection

1. Connect the wires from the PIR detector to the input pin, see *I/O connector on page 10*.
2. Connect the wires from the switch to the output pin, see *I/O connector on page 10*

Configure I/O ports

You need to connect the switch relay to the camera from the camera's web interface. First, configure the I/O ports:

Set the PIR detector to an input port

1. Go to **System > Accessories > I/O ports**.
2. Click  to set the direction to input for port 1.
3. Give the input module a descriptive name, for example "PIR detector".
4. If you want to trigger an event whenever the PIR detector senses motion, click  to set the normal state to circuit open.

Set the switch relay to an output port

1. Click  to set the direction to output for port 2.
2. Give the output module a descriptive name, for example "Gate switch".

AXIS T61 Mk II Audio and I/O Interface Series

Configure your device

3. If you want to open the gate whenever an event is triggered, click  to set the normal state to circuit closed.

Create rules

1. Go to **System > Events** and add a rule.
2. Type a name for the rule, for example "Open gate".
3. In the list of conditions, select **PIR detector**.
4. In the list of actions, select **Toggle I/O once**.
5. In the list of ports, select **Gate switch**.
6. Set state to **Active**.
7. Set the duration.
8. Click **Save**.

Detect tampering with input signal

This example explains how to send an email when the input signal is cut or short-circuited. For more information about the I/O connector, see *page 10*.

1. Go to **System > Accessories** and turn on **Supervised** for the relevant port.

Add an email recipient:

1. Go to **System > Events > Recipients** and add a recipient.
2. Type a name for the recipient.
3. Select **Email**.
4. Type an email address to send the email to.
5. The camera doesn't have its own email server, so it has to log into another email server to send mails. Fill in the rest of the information according to your email provider.
6. To send a test email, click **Test**.
7. Click **Save**.

Create a rule:

1. Go to **System > Events > Rules** and add a rule.
2. Type a name for the rule.
3. In the list of conditions, under **I/O**, select **Supervised input tampering is active**.
4. Select the relevant port.
5. In the list of actions, under **Notifications**, select **Send notification to email** and then select the recipient from the list.
6. Type a subject and a message for the email.
7. Click **Save**.

AXIS T61 Mk II Audio and I/O Interface Series

Configure your device

Audio

Add audio to your recording

Turn on audio:

1. Go to **Video > Stream > Audio** and include audio.
2. If the device has more than one input source, select the correct one in **Source**.
3. Go to **Audio > Device settings** and turn on the correct input source.
4. If you make any changes to the input source, click **Apply changes**.

Edit the stream profile that is used for the recording:

5. Go to **System > Stream profiles** and select the stream profile.
6. Select **Include audio** and turn it on.
7. Click **Save**.

Allow two-way audio communication

Note

When you have set up two-way audio communication in the camera's user interface, use a video management system to make use of the functionality.

This use case explains how to make it possible to communicate with audio through the product.

Connect a microphone and a speaker to the product:

1. Connect a microphone to the **Audio in** connector.
2. Connect a speaker to the **Audio out** connector.

Allow two-way audio in the camera's web page:

1. Go to **Video > Stream > Audio** and include audio.
2. Go to **Audio > Device settings** and make sure audio is allowed.
3. Turn on the correct input source.
4. If you make any changes to the input source, click **Apply changes**.
5. Go to **System > Plain config**.
6. Set **Select group** to **Audio**.
7. Make sure **Duplex mode** is set to **Full duplex**

AXIS T61 Mk II Audio and I/O Interface Series

Specifications

Specifications

Product overview

AXIS T6101 and AXIS T6112

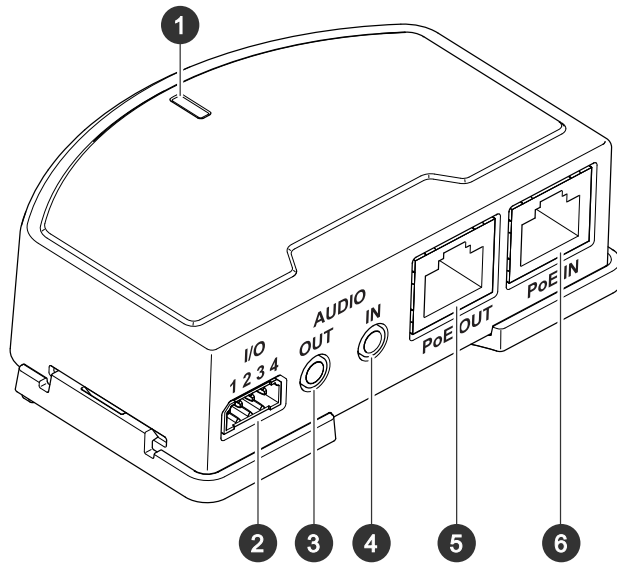

- 1 LED indicator
- 2 I/O connector
- 3 Audio out
- 4 Audio in
- 5 Network connector (PoE out)
- 6 Network connector (PoE in)

AXIS T61 Mk II Audio and I/O Interface Series

Specifications

AXIS T6112

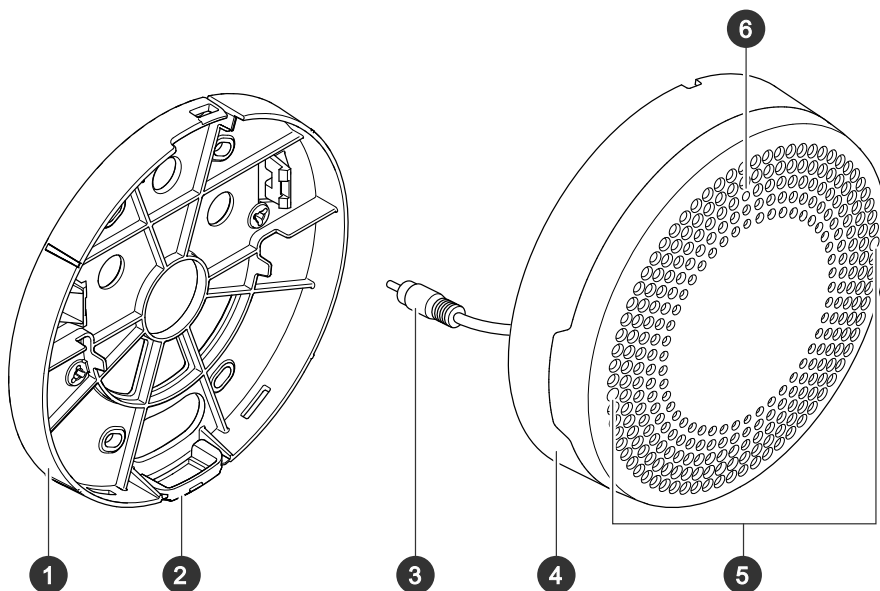

- 1 Bracket mount
- 2 Side lid
- 3 Microphone connector
- 4 Cover
- 5 Microphone
- 6 Status LED

Solution overview

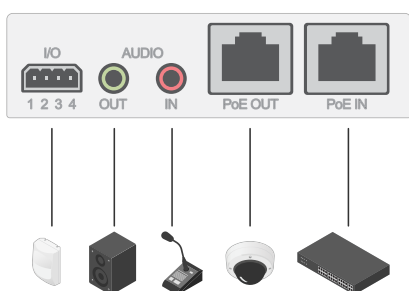

LED indicators

Status LED	Indication
Green	Steady green for normal operation.
Amber	Steady during startup. Flashes during firmware upgrade.

AXIS T61 Mk II Audio and I/O Interface Series

Specifications

Amber/Red	Flashes amber/red if network connection is unavailable or lost.
Red	Flashes red for firmware upgrade failure.

Connectors

Network connector

Input: RJ45 Ethernet connector with Power over Ethernet (PoE).

Output: RJ45 Ethernet connector with Power over Ethernet (PoE).

Audio connector

- **Audio in** – 3.5 mm input for a digital microphone, an analog mono microphone, or a line-in mono signal (left channel is used from a stereo signal).
- **Audio out** – 3.5 mm output for audio (line level) that can be connected to a public address (PA) system or an active speaker with a built-in amplifier. A stereo connector must be used for audio out.



Audio input

1 Tip	2 Ring	3 Sleeve
Unbalanced microphone (with or without electret power) or line	Electret power if selected	Ground
Digital signal	Ring power if selected	Ground

Audio output

1 Tip	2 Ring	3 Sleeve
Channel 1, unbalanced line, mono	Channel 1, unbalanced line, mono	Ground

I/O connector

Use the I/O connector with external devices in combination with, for example, motion detection, event triggering, and alarm notifications. In addition to the 0 V DC reference point and power (12 V DC output), the I/O connector provides the interface to:

Digital input – For connecting devices that can toggle between an open and closed circuit, for example PIR sensors, door/window contacts, and glass break detectors.

Supervised input – Enables possibility to detect tampering on a digital input.

Digital output – For connecting external devices such as relays and LEDs. Connected devices can be activated by the VAPIX® Application Programming Interface, through an event or from the device's web interface.

4-pin terminal block

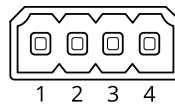

AXIS T61 Mk II Audio and I/O Interface Series

Specifications

Function	Pin	Notes	Specifications
DC ground	1		0 V DC
DC output	2	Can be used to power auxiliary equipment. Note: This pin can only be used as power out.	12 V DC Max load = 50 mA
Configurable (Input or Output)	3-4	Digital input or Supervised input – Connect to pin 1 to activate, or leave floating (unconnected) to deactivate. To use supervised input, install end-of-line resistors. See connection diagram for information about how to connect the resistors.	0 to max 30 V DC
		Digital output – Internally connected to pin 1 (DC ground) when active, and floating (unconnected) when inactive. If used with an inductive load, e.g., a relay, connect a diode in parallel with the load, to protect against voltage transients.	0 to max 30 V DC, open drain, 100 mA

Example

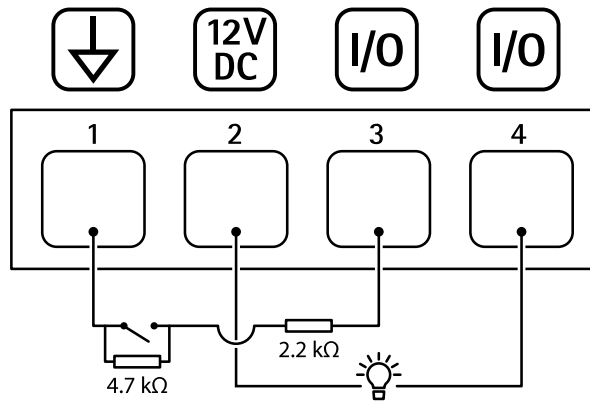

- 1 DC ground
- 2 DC output 12 V, max 50 mA
- 3 I/O configured as supervised input
- 4 I/O configured as output

AXIS T61 Mk II Audio and I/O Interface Series

Troubleshooting

Troubleshooting

Technical issues, clues and solutions

If you can't find what you're looking for here, try the troubleshooting section at axis.com/support

The Audio tab and I/O icon are not visible in the camera's webpage

The webpage is not updated. Refresh the browser window. If that does not help, clear the browser cache.

Wrong camera firmware version. Make sure that the camera has the latest firmware version installed. For information about how to check the camera's firmware version, see the camera's user manual.

The network connection is unavailable. Check the LED indicators on the product and compare with the LED indicators table on *page 9*.

The input and output network cables are connected to the wrong connectors. Interchange the input and output network cables.

The camera is not compatible. Go to the device's product page to see if your camera is compatible.

The Audio tab is visible but audio is not working

The camera has been disconnected from the Audio and I/O Interface. Reconnect the camera to the Audio and I/O Interface and refresh the camera's webpage.

No audio after connecting the camera to another audio source

The camera's stored audio source is outdated. Select a new audio source in **Source**.

The camera doesn't start up after connecting it to the product

Hardware issue. Contact Axis support.

The midspan is not properly connected. Make sure that all network cables are correctly connected. The Audio and I/O Interface must be connected to the camera through the midspan. Have a look at your product's installation guide for more information.

Contact support

Contact support at axis.com/support.

